

STIASA

Suministros Industriales del Tajo, S.A.

RÓTULAS

Índice de transmisión

Juntas universales a rótula



- de rodamientos de agujas (tipo V)
- de precisión (tipo A)
- ligera (tipo AL)
- Cubierta protectora flexible
- en acero inoxidable
- con cambio rápido
- Fórmula de selección
- Momentos de torsión
- Montaje y mantenimiento



Ejes y cubos estriados

Cruces cardan y figuras cardan



Articulación angular DIN 71802

Articulación esférica recta



Cabezas de rótula DIN 648 serie K



- acero/acero
- acero/bronce
- inoxidable
- inox integral AISI 316



Cabezas esféricas

Anillos elásticos en acero inoxidable



- DIN 6799
- DIN 471
- DIN 472

Chavetas (Anexo)

- UNI 6604 · DIN 6885
- UNI 6604 · DIN 6885 INOX
- UNI 6604 · DIN 6885 No normalizada
- UNI 6604/A · DIN 6885/A con largo especial
- UNI 6604/A · DIN 6885/A



Junta Universal a cruceta

- Ø 42
- Ø 55

Juntas universales Tipo V

Alta precisión con cojinete de
aguas

Junta universal de precisión
"alta velocidad" con cojinetes
de agujas y bajo
mantenimiento

DIN 7551

Ángulo máximo
Simple 45°
Doble 90°

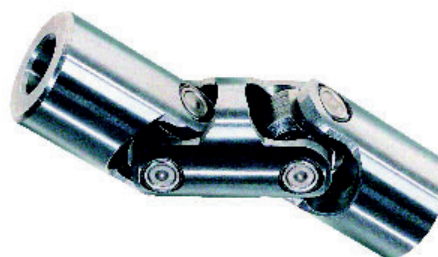
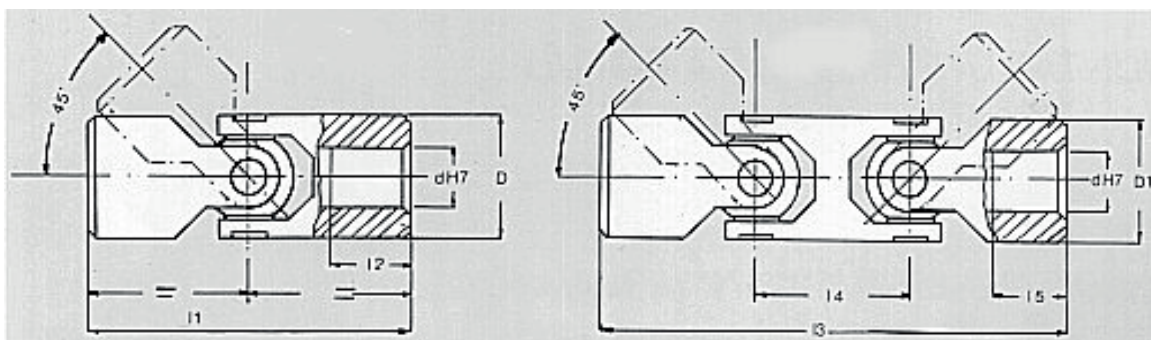

Tipo		d ^{H7}	D	l ₁	l ₂	D ₁	l ₃	l ₄	l ₅	b	t	s ^{H8}	W ^{H8}
S	D	mm	mm	mm	mm	mm	mm	mm	mm	mm	mm	mm	mm
102V		8	16	52	15					2	9		
103V	103DV	10	20	62	18	20	88	26	18	3	11,4	10	10
105V	105DV	14	25	74	20	25	104	33	20	5	16,3	14	14
106V	106DV	16	32	86	23	32	124	38	23	5	18,3	16	16
107V		18	37	72	17								
108V	108DV	20	40	108	30	40	156	48	30	6	22,8	20	20
109V		22	47	95	22								
110V	110DV	25	50	132	32	50	188	56	32	8	28,3	25	25
111V	111DV	30	63	166	38	63	238	80	38	8	33,3	30	30
112V	112DV	35	70	140	35	70	212	78	30	10	38,3		35
113V	113DV	40	80	180	50	80	290	120	48	12	43,3		35
114V	114DV	50	95	190	54	96	290	120	50	14	53,3		35

FORMA

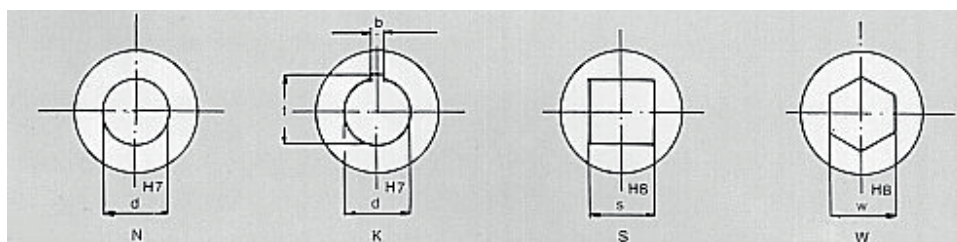

Juntas universales Tipo V

Conjunto cardan extensible con cojinete de agujas

Conjunto cardan extensible montado de juntas universales con cojinete de agujas

- Ejecución normal.
- Agujero redondo, con chavetero, hexágono o cuadrado.
- El eje estriado en la ejecución normal es trefilado.
- Bajo demanda puede ser fresado, templado y rectificado.

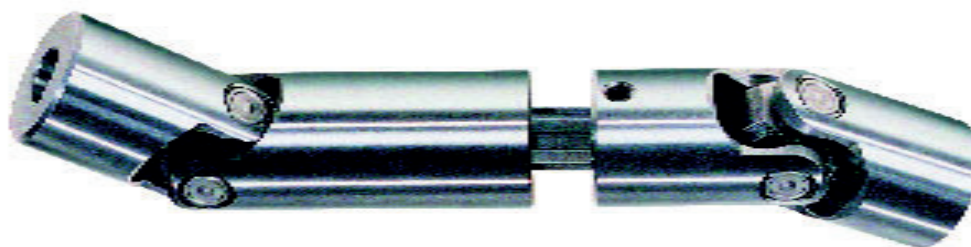
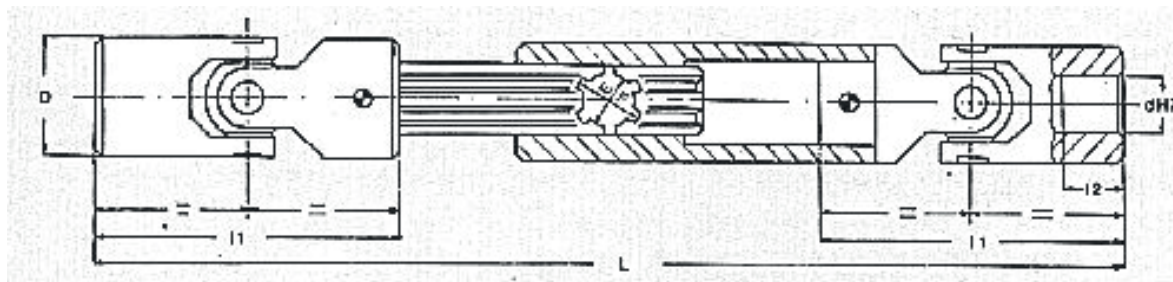

Medidas normalizadas

Tipo	D ^{H7} mm	D mm	l ₁ mm	l ₂ mm	bxt mm	s ^{H8} mm	SW ^{H8} mm	E mm	F mm	Lmin mm	Lmax mm
124V	8	16	52	15	2×9					146 186	166 246
125V	10	20	62	18	3×11,4	10	10	11	14	156 196	176 256
127V	14	25	74	20	5×16,3	14	14	13	16	187 237	217 307
128V	16	32	86	23	5×18,3	16	16	16	20	212 282	242 372
129V	18	37	72	17	6×20,8	17	18	16	20	195 270	225 370
130V	20	40	108	30	6×22,8	20	20	18	22	259 329	289 429
131V	22	47	95	22	6×24,8	22	22	21	25	250 330	280 430
132V	25	50	132	32	8×28,3	25	25	23	28	306 386	356 486
133V	30	63	166	38	8×33,3	30	30	32	38	386 466	456 576
134V	35	70	140	35	10×38,3		35	32	38		

Juntas universales Tipo A

Alta precisión DIN 808

Esta junta universal de "alta precisión" ha sido posible gracias a una esmerada construcción y de tolerancias ajustadísimas. Todas las partes de la articulación están templadas, rectificadas y lapeadas.

Ángulo máximo
Simple 45°
Doble 90°

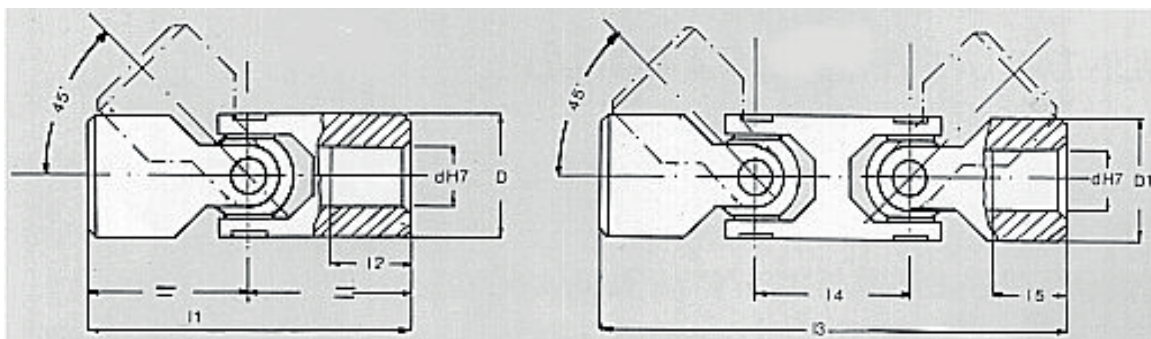

Tipo		d ^{H7}	D	l ₁	l _{1x}	l _{2x}	l ₂	D ₁	l ₃	l _{3x}	l ₄	l ₅	b	t	s ^{H8}	W ^{H8}
S	D	mm	mm	mm	mm	mm	mm	mm	mm	mm	mm	mm	mm	mm	mm	mm
101A	101AD	6	16	34			9	16	61		27					
102A	102AD	8	16	40	58		11	16	67		27		2	9		
103A	103AD	10	22	45	48	62	10	20	75		30		3	11,4	10	10
104A	104AD	12	25	50	56	74	11	22	74	86	29	15	4	13,8	12	12
105A	105AD	14	29	56	60	74	13	25	85	95	33	16	5	16,3	14	14
106A	106AD	16	32	65	68	86	15	29	100	104	35	19	5	18,3	16	16
107A	107AD	18	37	72	74	108	17	32	112	114	39	20	6	20,8	17	18
108A	108AD	20	40	82	108	127	19	40	127	128	46	20	6	22,8	20	20
109A	109AD	22	47	95	92	127	22	40	145		46	25	6	24,8	22	
110A	110AD	25	50	108	105	132	27	50	163		59	25	8	28,3	25	25
111A	111AD	30	58	122	166	178	30	58	182		66	30	8	33,3	30	30
111/1A	111/1AD	32	63	130			30	63	198		84	30	10	35,3	30	35
112A	112AD	35	70	140			35	70	212		78	30	10	38,3		35
113A	113AD	40	80	160			42	80	245		95	38	12	43,3		35
114A	114AD	50	95	190			54	95	290		120	50	14	53,8		35

l_{1x}, l_{2x}, l_{3x} longitud bajo demanda

FORMA

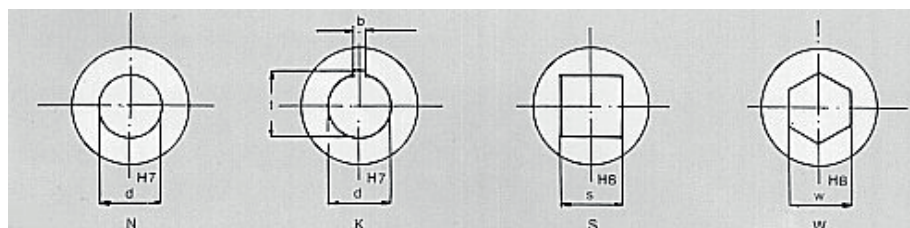

Juntas universales Tipo A

Conjunto cardan extensible

Conjunto cardan extensible montado
de juntas universales de precisión
DIN 808

- Ejecución normal.
- Agujero redondo, con chavetero, hexágono o cuadrado.
- El eje estriado en la ejecución normal es trefilado.
- Bajo demanda puede ser fresado, templado y rectificado.

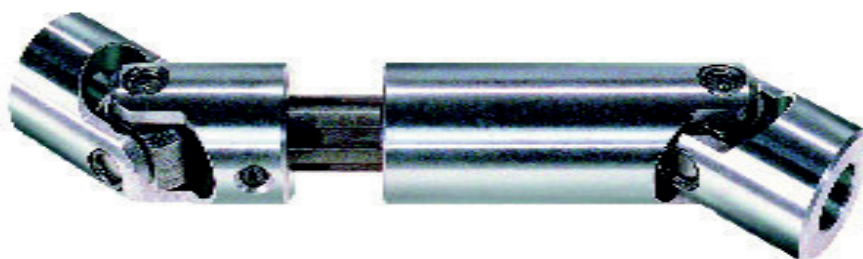
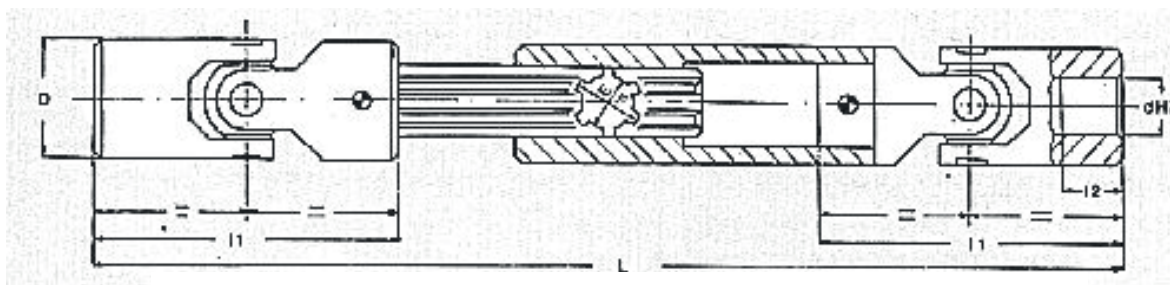

Tipo	D ^{H7} mm	D mm	l ₁ mm	l ₂ mm	B mm	bxt mm	s ^{H8} mm	SW ^{H8} mm	E mm	F mm	Lmin mm	Lmax mm
125A	10	22	45	10	40	3×11,4	10	10	11	14	130 170	150 230
126A	12	25	50	11	45	4×13,8	12	12	13	16	140 200	170 270
127A	14	29	56	13	48	5×16,3	14	14	13	16	160 210	190 280
128A	16	32	65	15	50	5×18,3	16	16	16	20	180 250	210 340
129A	18	37	72	17	51	6×20,8	17	18	16	20	195 270	225 370
130A	20	40	82	19	56	6×22,8	20	20	18	22	220 290	250 390
131A	22	47	95	22	60	6×24,8	22	22	21	25	250 330	280 430
132A	25	50	108	27	69	8×28,3	25	25	23	28	270 350	320 450
133A	30	58	122	30	70	8×33,3	30	35	26	32	320 400	390 510
134A	35	70	140	35	70	10×38,3	36	35	32	38		
135A	40	80	160	42	70	12×43,3	41	35	42	48		
136A	50	95	190	54	70	14×53,3	50	35	42	48		

Juntas universales

Tipo AL

Serie ligera

Ángulo máximo
Simple 45°
Doble 90°

La junta universal de la serie ligera es para trabajos de medias y bajas revoluciones.

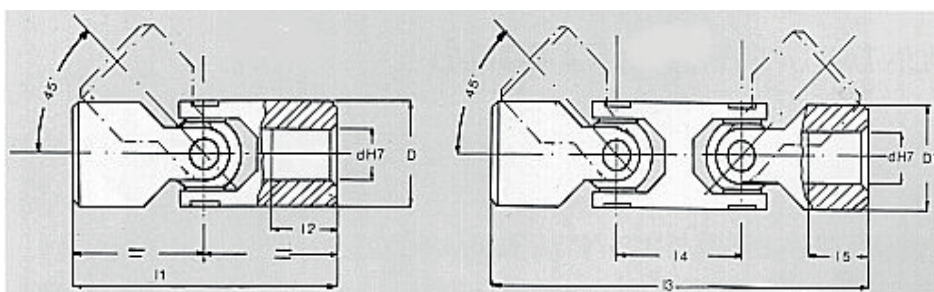

Tipo		d ^{H7}	D	D ₁	l ₁	l _{1x}	l _{2x}	l ₂	l ₃	l _{3x}	l ₄	l ₅	S	SW	b×t
S	D	mm	mm	mm	mm	mm	mm	mm	mm	mm	mm	mm	mm	mm	mm
100		5	10		40			13							
101AL	101ADL	6	13	13	40			13	63		23	13	6		
102AL	102ADL	8	16	16	40			10	67		27	10	8		2×9
103AL	103ADL	10	20	20	45	48	62	10	74		29	10	10	10	3×11,4
104AL	104ADL	12	25	22	50	56	74	11	74	86	29	11	12	12	4×13,8
105AL	105ADL	14	29	25	56	60	74	13	85	95	33	13	14	14	5×16,3
106AL	106ADL	16	32	29	65	68	86	15	100	104	35	19	16	16	5×18,3
107AL	107ADL	18	37	32	72	74		17	112	114	39	20	18	18	6×20,8
108AL	108ADL	20	40	40	82	108		19	128	127	46	19	20	20	6×22,8
109AL	109ADL	22	47	40	95	92		22	145		46	25	22		6×24,8
110AL	110ADL	25	50	50	108	105	132	27	163		59	24	25	25	8×28,3
111AL	111ADL	30	58	58	122	166		30	182		66	30	30	30	8×33,8

l_{1x}, l_{2x}, l_{3x} longitud bajo demanda

Juntas universales

Cubierta Protectora flexible

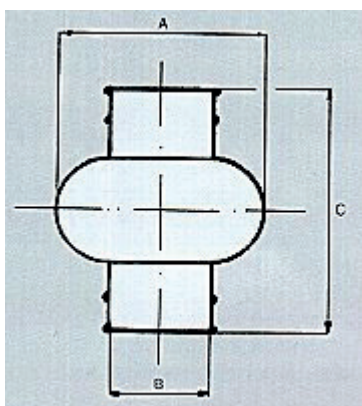

Tipo	ø est. Junta	Med. cubierta		
		A	B	C
103G	20/22	39	20,5	47
104G	25	47	24,5	52
105G	29	51	27,5	58
106G	32	56	30,5	67
107G	37	66	35,5	74
108G	40	75	40	84
109G	47	83	45	97
110G	50	93	50	110
111G	58	105	56	124

Juntas universales Tipo X

En acero inoxidable

Construidas en acero inoxidable X5Cr Ni1810 AISI 304

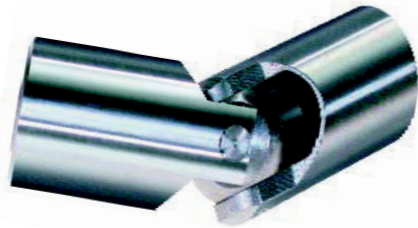
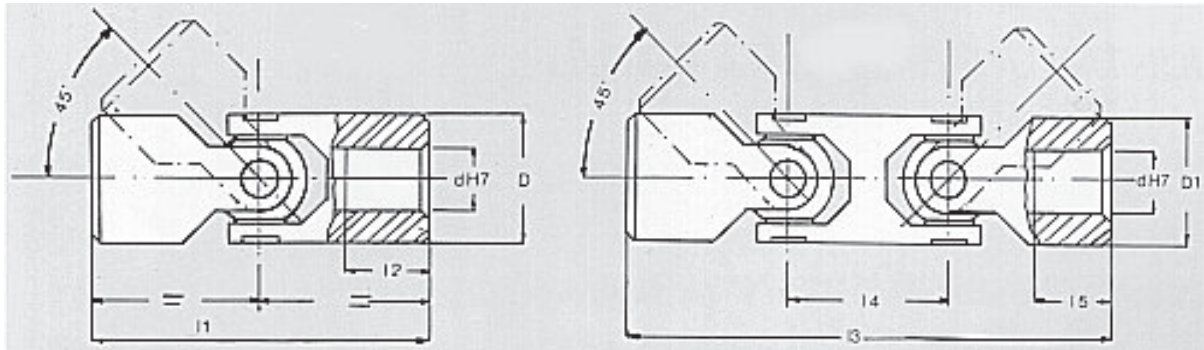

Junta simple 45°					Junta doble 90°						Acoplamiento bajo demanda		
Tipo	d ^{H7}	D	L1	L2	Tipo	d ^{H7}	D1	L3	L4	L5	S	SW	bxt
100X	5	10	44	15									
101X	6	13	50	18							6		
102X	8	16	58	19							8		2x9
103X	10	22	76	19							10	10	3x11,4
104X	12	25	86	29	104DX	12	22	105	29	29	12	12	4x13,8
105X	14	29	90	30	105DX	14	25	119	33	30	14	14	5x16,3
106X	16	32	95	30	106DX	16	29	125	35	30	16	16	5x18,3
107X	18	37	108	35	107DX	18	32	134	39	35	18	18	6x20,8
108X	20	40	108	32	108DX	20	40	154	46	32	20	20	6x22,8
109X	22	47	127	38	109DX	22	40	173	46	38	22		6x24,8
110X	25	50	140	44	110DX	25	50	199	59	44	25	25	8x28,3
111X	30	58	178	58	111DX	30	58	244	66	58	30	30	8x33,8

FORMA

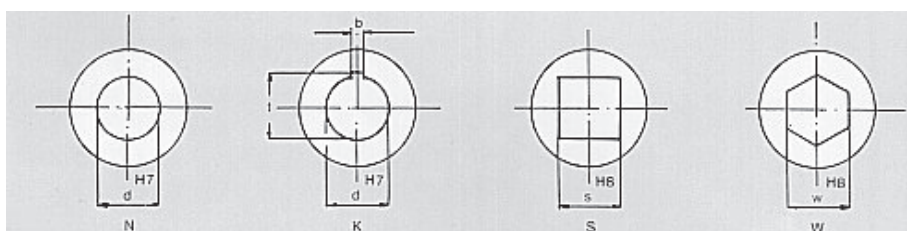

Juntas universales Tipo VR

Alta precisión con cojinete de
aguja y cambio rápido

Con rodamientos de agujas y cambio rápido

Ángulo máximo

Simple 45°

Doble 90°

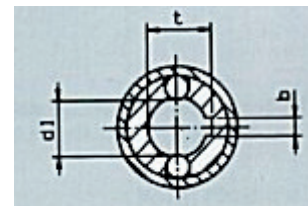
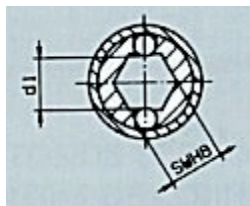
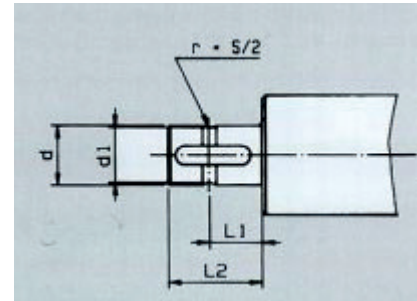
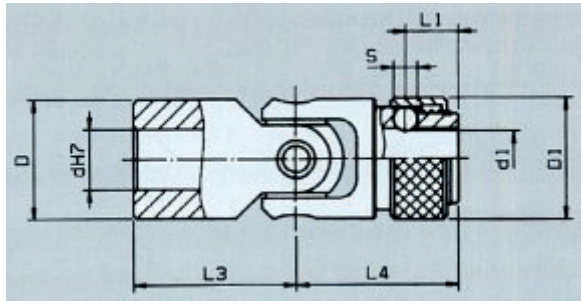

Tipo	d ^{H7} mm	D mm	d ₁ mm	D ₁ mm	l ₁	l ₂	l ₃	l ₄	S mm	b mm	t mm	SW ^{H8}	SW ₁ ^{H8}
102VR	8	16	6,3	16	9,5	15	26	26	3	2	9		
103VR	10	20	8,7	22	11,5	18	31	31	4	3	11,2	10	9,06
105VR	14	25	13	26,5	13,5	21	37	37	4	5	15,3	14	11,5
106VR	16	32	14,8	32,5	14	25	43	43	6,3	5	17,3	16	
107VR	18	37	16	37	19	33	36	50	8	6	19,8	18	
108VR	20	40	18	40,5	19	33	54	54	8	6	21,8	20	
109VR	22	47	20	47	20,5	38	47,5	60	10	6	23,8	22	
110VR	25	50	23	50,5	20,5	38	66	66	10	8	26,8	25	
111VR	30	63	28	63,5	25	50	83	83	10	8	32,2	30	

FORMA

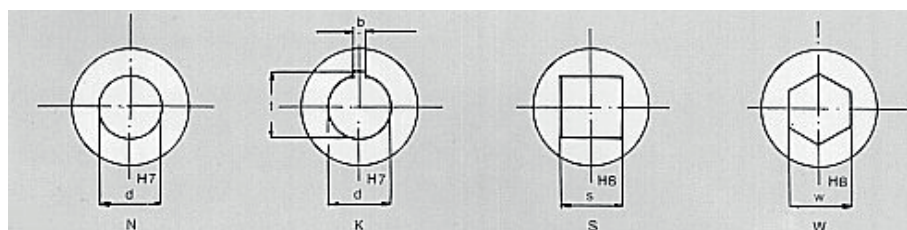

Juntas universales

Tipo AR

Alta precisión con cambio rápido

Alta precisión y cambio rápido

Ángulo máximo
Simple 45°
Doble 90°

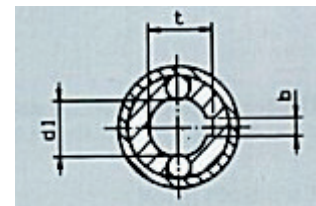
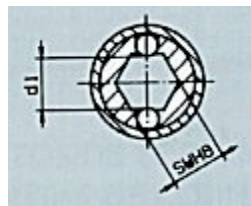
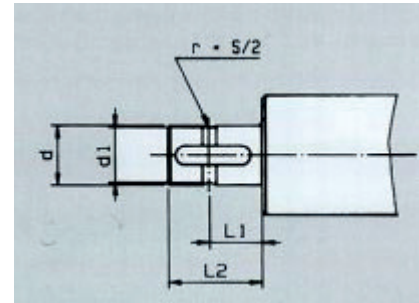
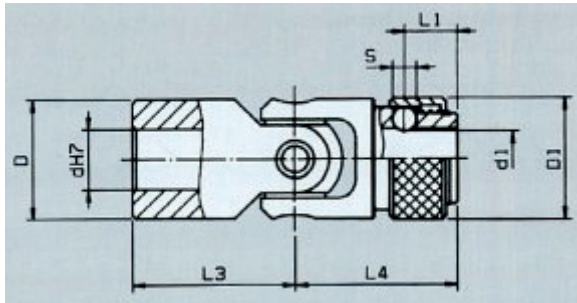

Tipo	d ^{H7} mm	D mm	d ₁ mm	D ₁ mm	l ₁	l ₂	l ₃	l ₄	S mm	b mm	t mm	SW ^{H8}	SW ₁ ^{H8}
103AR	10	22	8,7	22	11,5	17	22,5	31	4	3	11,2	10	9,06
104AR	12	25	11	26	13,5	21	25	37	4	4	13,3	12	
105AR	14	29	13	29	13,5	21	28	37	4	5	15,3	14	11,5
106AR	16	32	14,8	32	14	25	32,5	43	6,3	5	17,3	16	
107AR	18	37	16	37	19	33	36	50	8	6	19,8	18	
108AR	20	40	18	40	19	33	41	54	8	6	21,8	20	
109AR	22	47	20	47	20,5	38	47,5	60	10	6	23,8	22	
110AR	25	50	23	50	20,5	38	54	66	10	8	26,8	25	
111AR	30	58	28	58	25	50	61	83	10	8	32,2	30	

FORMA

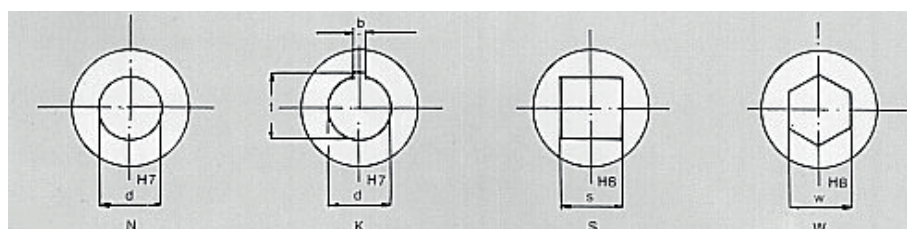

Juntas universales

**Criterios para escoger
las juntas adecuadas
a sus necesidades**

Las tablas presentan los pares de torsión máximos permitidos (expresadas en Kgm.), que han sido calculados tras un funcionamiento prolongado con un ángulo de inclinación de 10°. Si el ángulo de inclinación superase los 10°, los valores respectivos se reducirán de acuerdo a los factores de par de torsión indicados a continuación.

Ángulo A	Factor F
5°	1,25
10°	1
20°	0,75
30°	0,45
40°	0,30

Ejemplo

Criterios de elección de la junta apropiada, según la potencia que se quiere transmitir, la velocidad y el ángulo de inclinación.

Considerando:

- La potencia N 3CV
- La velocidad n 2000 revoluciones/min.
- El ángulo a 20°

El correspondiente momento de torsión es:

$$M_t = \frac{716,2 \times N}{n} = \frac{716,2 \times 3}{2000} = 1,074 \text{ Kgm.}$$

El par de torsión a transmitir es de 1,074 Kgm., pero puesto que el ángulo es de 20° habrá que elegir una junta de mayor dimensión, con un par de torsión más elevado. Puesto que el factor de par de torsión para 20° es de 0,75 (según lo indicado en la tabla), habrá que dividir el M_t por F:

$$\frac{M_t}{F} = \frac{1,074}{0,75} = 1,432 \text{ Kgm.}$$

La junta apropiada deberá tener un par de torsión de transmisión de 1,432 Kgm. que, según lo que indica la tabla de juntas de cojinetes, es del tipo 105V.

Hay que tener en cuenta que 1 Kgm. = 9,80665 Nm.

Momentos de torsión (en Nm) para juntas cardan de precisión de casquillos

Tipo	VELOCIDAD min 1						
	100	200	300	400	500	700	800
103A - 103AR - 125A	25	17	14,5	13	12	11	7,5
104A - 104AR - 126A	43	25	20,5	17	15,5	13	12
105A - 105AR - 127A	68,5	43	39,5	36	33,5	28,5	26,5
106A - 106AR - 128A	86,5	84	72	57,5	51,5	41	36
107A - 107AR - 129A	156	120	96	72	60	48	
108A - 108AR - 130A	240	168	120	96	84	60	
109A - 109AR - 131A	300	192	144	120	96	72	
110A - 110AR - 132A	384	240	168	144	120	96	
111A - 111AR - 133A	432	264	192	156	132		
112A - 134A	456	300	228	174	144		
113A - 135A	504	336	264	216			
114A - 136A	720	480	336	264			

Para las juntas dobles utilizar el valor equivalente al 90% de los momentos de torsión mencionados

Momentos de torsión (en Nm) para juntas de cojinetes de aguja

Tipo	VELOCIDAD min 1					
	250	500	1000	2000	3000	4000
103V - 103VR - 125V				5,8		
104V - 104VR - 126V	22	17	14	11	10	9
105V - 105VR - 127V	34	29	24	22	20	18
106V - 106VR - 128V	65	55	45	40	37	32
107V - 107VR - 129V	75	61	50	45	40	36
108V - 108VR - 130V	140	120	100	80	70	65
109V - 109VR - 131V	162	132	108	88	77	71
110V - 110VR - 132V	200	170	130	110	90	85
111V - 111VR - 133V	300	270	230	190	160	140
112V - 134V	326	277	237	198	168	
113V - 135V	365	303	255	205	186	
114V - 136V	402	335	275	225	198	

Para las juntas dobles utilizar el valor equivalente al 90% de los momentos de torsión mencionados

Momentos de torsión (en Nm) para juntas de acero inoxidable

VELOCIDAD min 1

Tipo	100	200	300	400	500	700	800
100X	3,6	3,3	2,8	2,5	2,3		
101X	4,4	4,4	3,5	3,2	2,9		
102X	8,6	6	5,3	4,6	4	3,4	3,1
103X	12,3	8,3	7	6,4	5,8	5,2	3,5
104X	21	12,6	10	8	7,3	6,3	5,8
105X	33	21,3	19,3	17,6	16,3	13,3	12,6
106X	45	42	35,3	29	25,3	20	17,3
107X	76	60	46,6	35,3	29,3	23,3	
108X	117	84	58,6	46,6	41,3	29,3	
109X	146	96	70	58,6	46,6	35,3	
110X	192	120	84	72	60	48	
111X	216	132	96	78	66		

Para las juntas dobles utilizar el valor equivalente al 90% de los momentos de torsión mencionados

Momentos de torsión (en Nm) para juntas de serie ligera

VELOCIDAD min 1

Tipo		100	200	300	400	500	700	800
	100AL	5.5	5	4.2	3.8	3.5		
	101AL	6.6	6.6	5.3	4.8	4.4		
	102AL	13	9	8	7	6	5.2	4.7
125AL	103AL	18.5	12.5	10.5	9.7	8.8	7.9	5.3
126AL	104AL	31.5	19	15	12	11	9.5	8.8
127AL	105AL	50	32	29	26.5	24.5	20	19
128AL	106AL	68	63	53	42	38	30	26
129AL	107AL	114	90	70	53	44	35	
130AL	108AL	176	126	88	70	62	44	
131AL	109AL	220	144	105	88	70	53	
132AL	110AL	288	180	126	108	90	72	
133AL	111AL	324	198	144	117	99		

Para las juntas dobles utilizar el valor equivalente al 90% de los momentos de torsión mencionados

Las horquillas de las juntas deben estar en el mismo plano, de acuerdo al esquema siguiente. Un montaje incorrecto de las juntas producirá un movimiento no uniforme.

Correcto

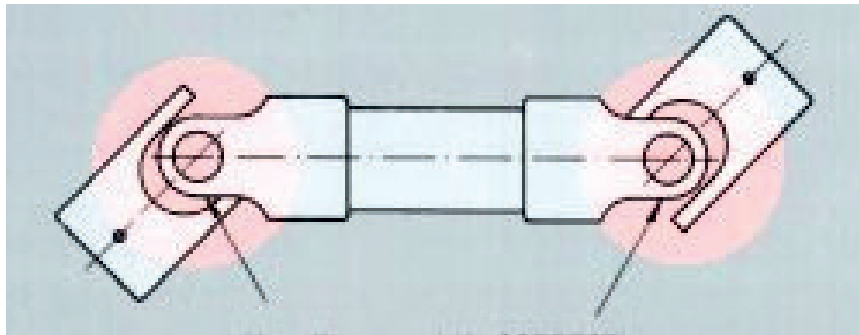

Incorrecto

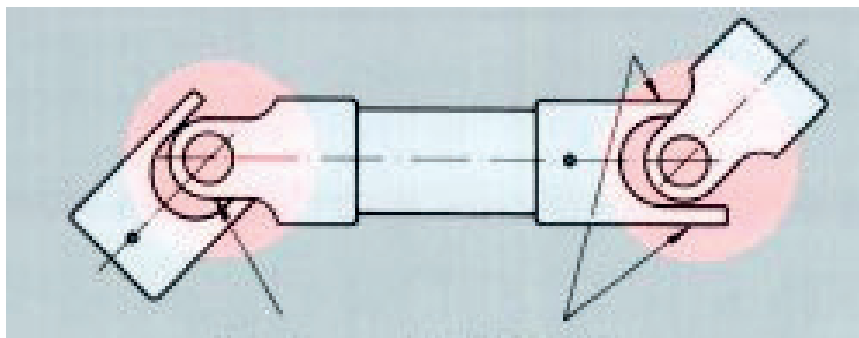

- Para montar las juntas con los árboles, se debe practicar el agujero a 90° sobre la línea mediana de las horquillas exteriores e interiores, que deben estar alineadas.
- El mantenimiento de las juntas universales se limita a una lubricación adecuada, que debe practicarse como mínimo una vez al mes.
- En los ambiente polvorientos es aconsejable proteger las juntas con unos casquetes de goma que, además de protegerlas de la contaminación ambiental, facilitan un proceso continuo de autolubricación, mediante la grasa que se acumula en su interior

Ejes y cubos estriados

Ejes estriados DIN 5463

Ref.:	$\varnothing D$ -0,07 -0,27	$\varnothing d$ -0,00 -0,07	Z	C +0,00 -0,08	Sección mm ²	Peso Kg/m
SEE-14	14	11	6	3	121,9	0,95
SEE-16	16	13	6	3,5	164,1	1,28
SEE-20	20	16	6	4	243,4	1,91
SEE-22	22	18	6	5	312,4	2,45
SEE-25	25	21	6	5	399,8	3,14
SEE-28	28	23	6	6	505,2	3,96
SEE-32	32	26	6	6	638,6	5,00
SEE-38	38	32	8	6	947,8	7,43
SEE-48	48	42	8	8	1576,7	12,37

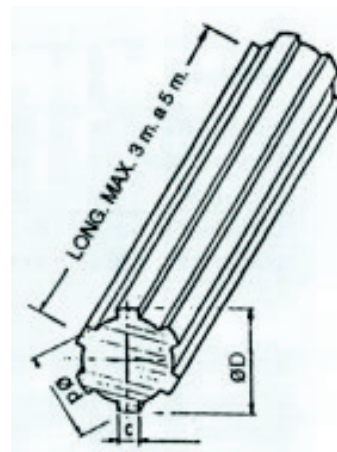

Cubo con brida de fijación

Ref.:	Perfil	Ø D ₁	Ø D ₂	Ø D ₃	L	B	Tal.fijac.	
							Ø M	Nº Tal.
SCBA-14	11X14	60	50	38	25	10	M-6	3
SCBA-16	13X16	70	55	42	35	12	M-6	4
SCBA-20	16X20	80	65	52	40	12	M-6	4
SCBA-25	21X25	80	65	52	40	12	M-6	4
SCBA-32	26X32	100	82	65	50	16	M-8	4

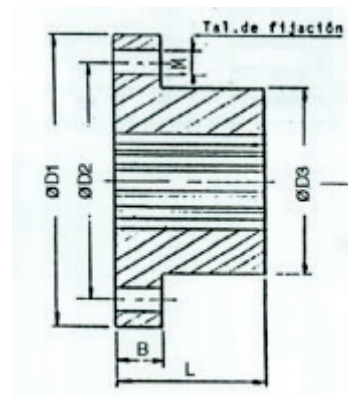

Casquillo estriado

Ref.:	$\varnothing D$	L
SCB-14	28	25
SCB-16	33	35
SCB-20	38	40
SCB-22	33	45
SCB-25	48	40
SCB-28	41	48
SCB-32	58	50
SCB-38	65	60
SCB-48	78	82

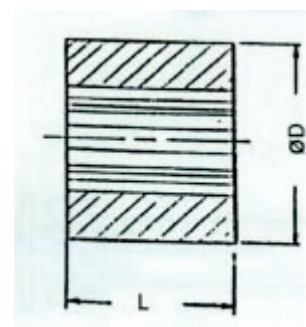

Ejes y cubos estriados INOXIDABLES



Ejes estriados DIN 5463

AISI 304

Ref.:	$\varnothing D$ -0,07 -0,27	$\varnothing d$ -0,00 -0,07	Z	C +0,00 -0,08	Sección mm ²	Peso Kg/m
SEEX-14	14	11	6	3	121,9	0,95
SEEX-16	16	13	6	3,5	164,1	1,28
SEEX-20	20	16	6	4	243,4	1,91
SEEX-22	22	18	6	5	312,4	2,45
SEEX-25	25	21	6	5	399,8	3,14
SEEX-28	28	23	6	6	505,2	3,96

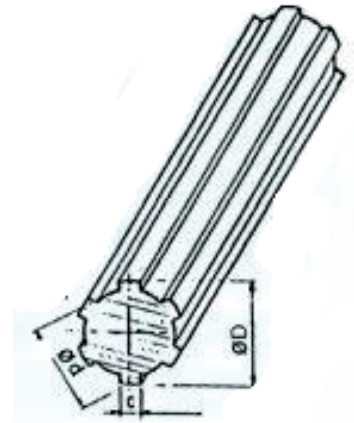

En barras de 1 metro

Casquillo estriado

AISI 303

Ref.:	$\varnothing D$	L
SCBX-14	19,5	30
SCBX-16	23	35
SCBX-20	33	35
SCBX-22	33	40
SCBX-25	40	40
SCBX-28	41	48

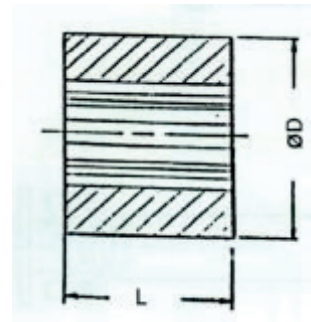

Transmisión Cardan

Cardans y cruces cardan

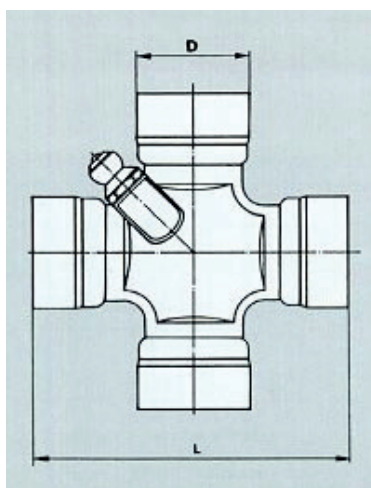
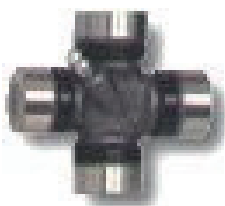

Ver catálogo transmisión cardan

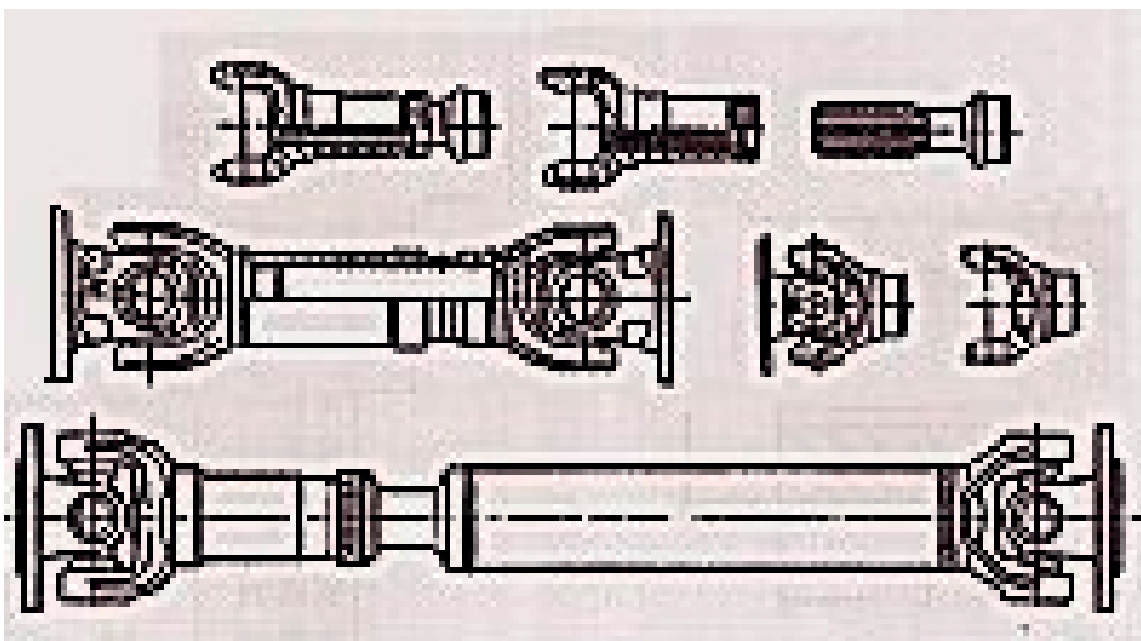

Articulación Angular

DIN 71802
Acabado cincado

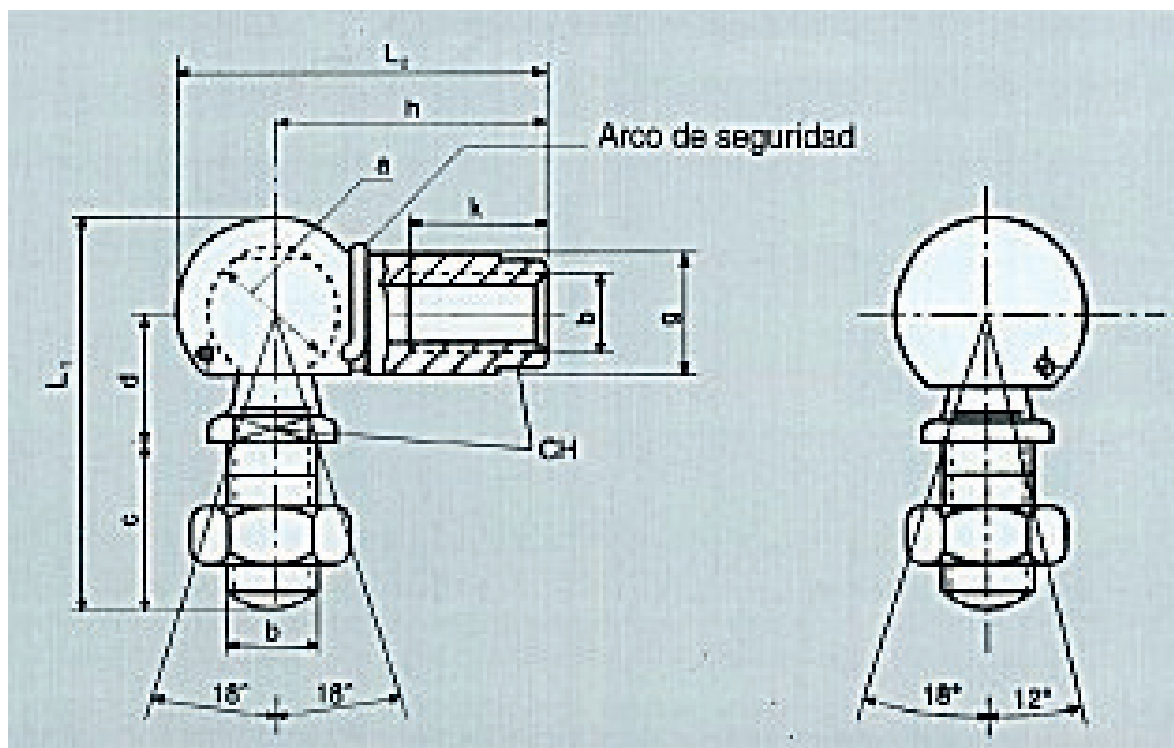

a	b	c	d	g	h	L ₁	L ₂	k	CH	Peso
8	M5	10	9	8	22	25.2	28.5	10.2		14.4
10	M6	12.5	11	10	25	30.2	32.5	11.5	8	25.2
13	M8	16.5	13	13	30	38.2	39.5	16	11	53.1
16	M10	20	16	16	35	47.5	47	15.5	13	103.8
19	M14×1,5	28	21	22	45	62.5	60	21.5		209.8

Existen dos versiones de la articulación angular. La versión con arco de seguridad (**forma AS**) y la versión sin el arco o anillo de seguridad (**forma A**)

Ejemplo de pedido: Se precisa una articulación angular con arco de seguridad de espiga rosca M10: AS16M10

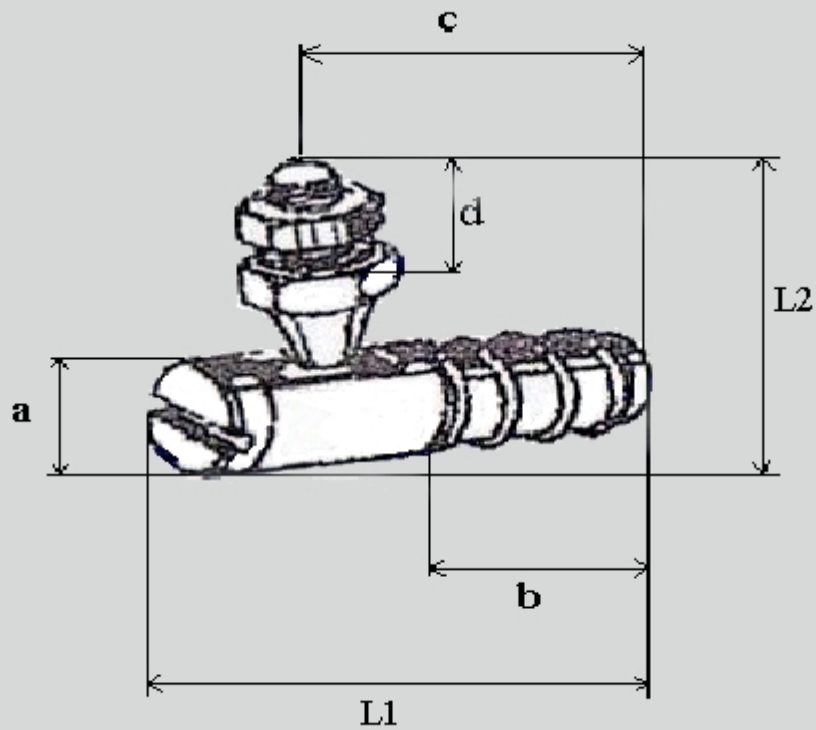

REF.	DIMENSIONES EN mm						rosca muelle	rosca bola
	a	b	c	d	L1	L2		
ATM720M5	13	15	20,5	13	31	35	M.5	M.5
ATM721M6	13	15	20,5	13	31	35	M.6	M6
ATM72101	13	15	20,5	13	31	35	M.6	M.8
ATM722M8	15	18	26	15	39	40	M.8	M.8
ATM72201	15	18	26	15	39	40	M.8	M.10
ATM72300	17	20	27,5	17	39	45	M.10	M.8
ATM723M10	17	20	27,5	17	39	45	M.10	M.10

Articulación Esférica Recta

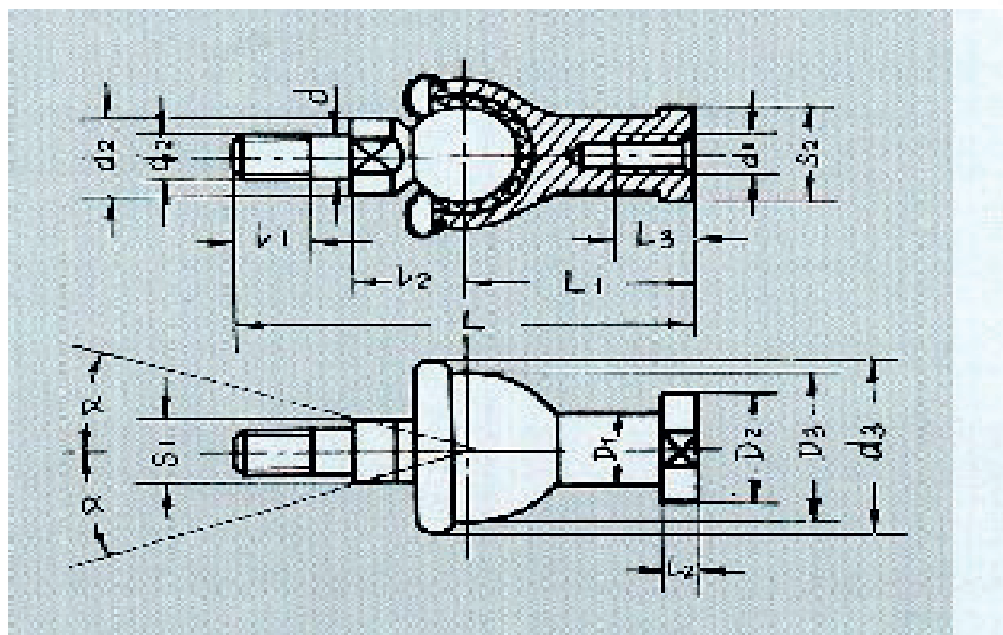

REF.	DIMENSIONES EN mm															CARGA		α^* N	Peso Kg.
	d	d ₁	d ₂ min	d ₃ max	l ₁ min	l ₂	S ₁	L max	L ₁	L ₂ max	L ₃ min	D ₁ max	D ₂ max	D ₃ max	S ₂	Din. KN	Est. KN		
SQZ5C	5	M5	9	20	8	11	7	46	24	4	12	9	12	17	10	1.7	5.7	15	0.025
SQZ6C	6	M6	10	20	11	12.2	8	55.2	28	5	13	10	13	20	10	2.2	7.5	15	0.040
SQZ8C	8	M8	12	24	12	16	10	65	32	5	16	12.5	16	24	13	3.3	11	15	0.075
SQZ10C	10	M10×1.25	14	30	15	19.5	11	74.5	35	6.5	19	15	19	28	16	4.8	16	15	0.121
SQZ12C	12	M12×1.25	19	32	17	21	16	84	40	6.5	22	17.5	22	32	18	6.6	22	15	0.187
SQZ14C	14	M14×1.5	19	38	22	23.5	16	104.5	45	8	25	20	25	36	21	8.7	29	11	0.277
SQZ16C	16	M16×1.5	22	44	23	25.5	18	112	50	8	27	22	27	40	24	10	33	11	0.361
SQZ18C	18	M18×1.5	25	45	25	31	21	130.5	58	10	32	25	31	45	27	11	37	11	0.539
SQZ20C	20	M20×1.5	29	50	25	31	24	133	63	10	38	27.5	34	45	30	11	37	7.5	0.575
SQZ22C	22	M22×1.5	29	52	26	33	24	145	70	12	43	30	37	50	30	14	46	7.5	0.757

C = Acoplamiento del acero SF1 sobre la superficie esférica

Acoplamiento esférico prelubricado, guarnición de retención en neopreno.

Cabezas de Rótula

Serie CF (Hembra)

Fabricadas según norma DIN ISO 12240 – 4 serie K.
Para cilindros neumáticos, rosca norma ISO 8139 (Cetop)

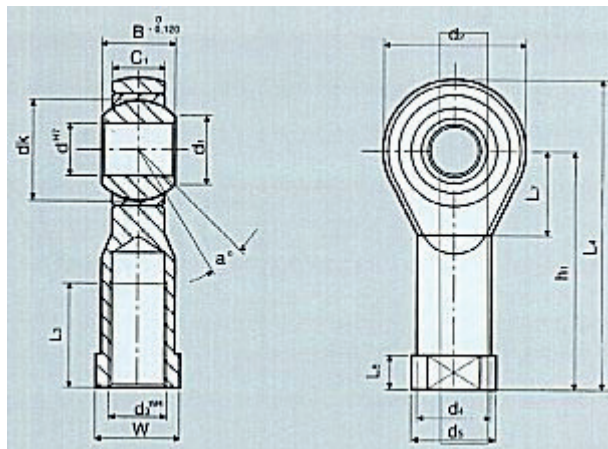

- Autolubricante, sin mantenimiento.
- Reducido incremento de holgura durante el funcionamiento.
- Valores de par resistentes y constantes con el tiempo.
- Posibilidad de funcionamiento en contacto o inmersión de aceite.
- Temperatura de funcionamiento: - 30°C +150°C

Referencia	d mm	d ₃	B	C ₁	d ₁	d ₂	d ₄	d ₅	d _k	h ₁	L ₃	L ₄	L ₅	L ₇	W	carga estática Co(daN)	áng.	Peso kg.
CF05M04	5	M4	8	6	7,7	18	9	11	11,112	27	10	36	4	10	9	600	13	0,018
CF05M05	5	M5	8	6	7,7	18	9	11	11,112	27	10	36	4	10	9	600	13	0,019
CF06M06	6	M6	9	6,75	8,9	20	10	13	12,7	30	12	40	5	11	11	700	13	0,026
CF08M08	8	M8	12	9	10,4	24	12,5	16	15,875	36	16	48	5	13	14	1200	14	0,046
CF10M10	10	M10	14	10,5	12,9	28	15	19	19,05	43	20	57	6,5	15	17	1400	13	0,076
CF10M10×1,25	10	M10×1,25	14	10,5	12,9	28	15	19	19,05	43	20	57	6,5	15	17	1400	13	0,076
CF12M12	12	M12	16	12	15,4	32	17,5	22	22,225	50	22	66	6,5	17	19	1900	13	0,110
CF12M12×1,25	12	M12×1,25	16	12	15,4	32	17,5	22	22,225	50	22	66	6,5	17	19	1900	13	0,110
CF16M16	16	M16	21	15	19,3	42	22	27	28,575	64	28	85	8	23	22	4800	15	0,220
CF16M16×1,5	16	M16×1,5	21	15	19,3	42	22	27	28,575	64	28	85	8	23	22	4800	15	0,220
CF20M20×1,5	20	M20×1,5	25	18	24,3	50	27,5	34	34,925	77	33	102	10	27	30	5200	14	0,409
CF30M27×2	30	M27×2	37	25	34,8	70	40	50	50,8	110	51	145	15	36	41	10800	17	1,200
CF30M30×2	30	M30×2	37	25	34,8	70	40	50	50,8	110	51	145	15,5	36	41	10800	17	1,140
CF35M36×2	35	M36×2	43	28	37,7	80	46	58	57,15	125	56	165	17	41	50	12400	19	1,600

La referencia para cabezas de rótula con rosca izquierda: CFL...

Acoplamiento de frotación: Acero en bronce sin mantenimiento.

Esfera: Acero por cojinete 100Cr, templado, rectificado y pulido.

Anillo externo: Bronce especial autolubrificante formado en la esfera en frío.

Cuerpo externo: Hasta la medida 12, viene producido en acero torneado y las sucesivas en acero bonificado y ft La superficie es zincada y cromatizada; la articulación és embutida en la cabeza, y esta, a su vez, recalca lateralmente para evitar desplazamientos axiales.

Cabezas de Rótula

Serie CM (Macho)

Fabricadas según norma DIN ISO 12240 – 4 serie K.
Para cilindros neumáticos, rosca norma ISO 8139 (Cetop)

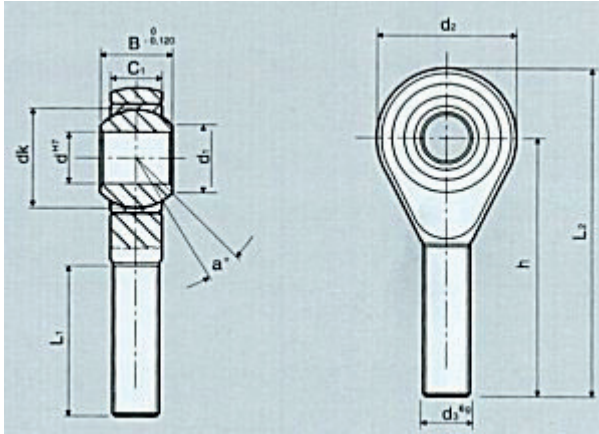

- Autolubricante, sin mantenimiento.
- Reducido incremento de holgura durante el funcionamiento.
- Valores de par resistentes y constantes con el tiempo.
- Posibilidad de funcionamiento en contacto o inmersión de aceite.
- Temperatura de funcionamiento: -30°C +150°C

Referencia	d mm	d ₃	B	C ₁	d ₁	d ₂	d _k	h	L ₁	L ₂	carga estática Co(daN)	áng.	Peso kg.
CM05M05	5	M5	8	6	7,7	18	11,112	33	19	42	300	13	0,015
CM06M06	6	M6	9	6,75	8,9	20	12,7	36	21	46	400	13	0,022
CM08M08	8	M8	12	9	10,4	24	15,875	42	25	54	800	14	0,038
CM10M10	10	M10	14	10,5	12,9	28	19,05	48	28	62	1300	13	0,063
CM12M12	12	M12	16	12	15,4	32	22,225	54	32	70	1700	13	0,100
CM16M16	16	M16	21	15	19,3	42	28,575	66	37	87	4800	15	0,195
CM20M20×1,5	20	M20×1,5	25	18	24,3	50	34,925	78	45	103	5200	14	0,370
CM30M30×2	30	M30×2	37	25	34,8	70	50,8	110	66	145	10800	17	1,060
CM35M36×2	35	M36×2	43	28	37,7	80	57,15	140	85	180	12400	19	1,640

(1) La referencia para cabezas de rótula con rosca izquierda: CML...

Carga máxima admitida en la cabeza

En base al tipo de carga de la articulación, expuesta a la cabeza es indispensable controlar la demanda admitida. Al par de carga nominal, las cargas dinámicas provocan una mayor demanda en la cabeza de la rótula respecto a las cargas constantes. Es por tanto necesario introducir los siguientes coeficientes en el cálculo de la carga admisible.

Tipo de carga	Carga	Cofic. Carga Kf
Constante		1
Dinámico simple		0,5
Dinámico alterno		0,25

- $F_{amm} = Co \times Kf$
carga máxima admitida en la cabeza de la articulación (daN)
- Co = carga estática de las cabezas
- Kf = coeficiente de carga
- Fr = fuerza radial (daN)

Cabezas esférica

Norma DIN 648 serie K

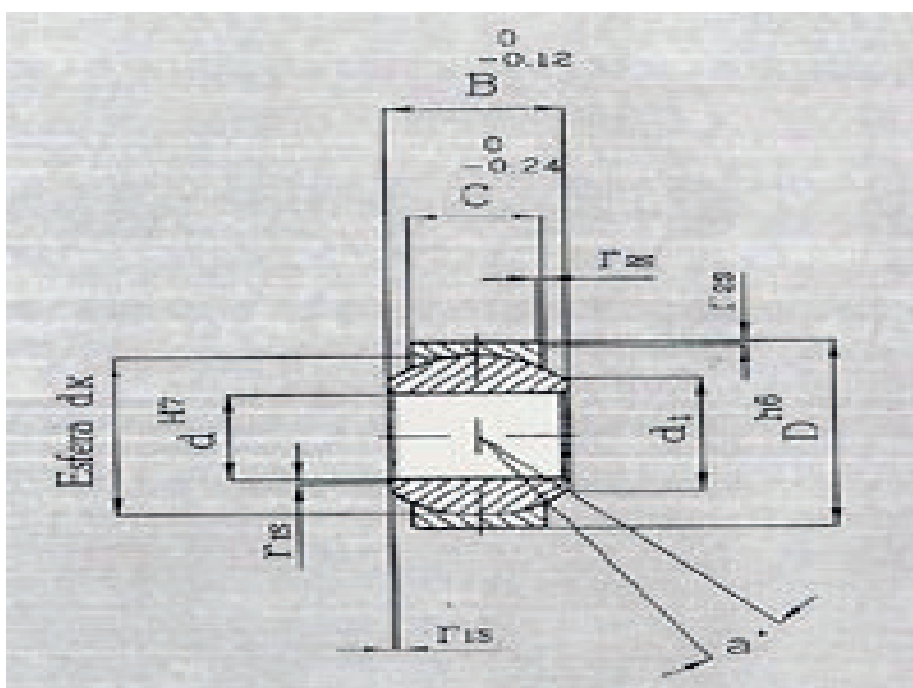

Denom.	d mm	B	C	D	d ₁	d _k	r ₁ smin. r ₂ smin.	Carga estática Co(daN)	áng. °	Peso Kg
G5	5	8	6	13	7.7	11.112	0.3	1300	13	0.006
G6	6	9	6.75	16	8.9	12.7	0.3	1700	13	0.009
G8	8	12	9	19	10.4	15.875	0.3	2800	14	0.016
G10	10	14	10.5	22	12.9	19.05	0.3	4000	13	0.025
G12	12	16	12	26	15.4	22.225	0.3	5300	13	0.040
G16	16	21	15	32	19.3	28.575	0.3	8500	15	0.080
G20	20	25	18	40	24.3	34.925	0.3	12500	14	0.150
G30	30	37	25	55	34.8	50.8	0.6	25400	17	0.380
G35	35	43	28	62	37.7	57.15	0.6	32000	19	0.490

Anillos elásticos en acero inoxidable

DIN 6799

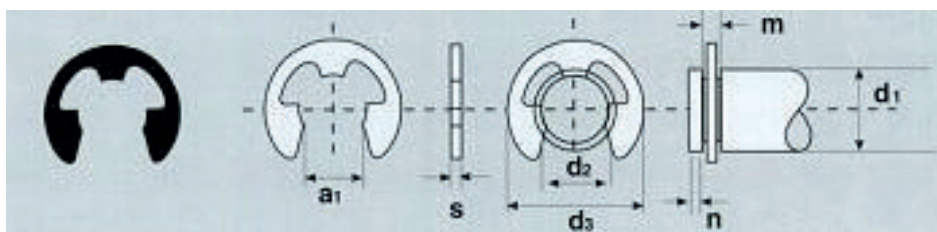

Dimensión ranura					Dimensión anillo					Peso kg/1000	Anillos sueltos		Anillos montados en ejes	
d ₂ h11	d ₁		n min	m	d ₃ max	S	a1				cantidad por caja	cantidad por eje	cantidad por caja	
1,5	2	2,5	0,8	0,44	^{+0,04} -0	4,25	0,4	1,28	±0,04	0,018		900	100000	
1,9	2,5	3	1	0,54	+0,04 -0	4,8	0,5	1,61		0,028		700	100000	
2,3	3	4	1	0,64		6,3	0,5	1,94	0,061		600	48000		
3,2	4	5	1	0,64		7,3	0,5	2,70	±0,048	0,075		600	36000	
4	5	7	1,2	0,74		9,3	0,7	3,34		0,151		500	15000	
5	6	8	1,2	0,74		11,3	0,7	4,11	0,225		500	12000		
6	7	9	1,2	0,74		12,3	0,7	5,26	0,240		500	10000		
7	8	11	1,5	0,94		14,3	0,9	5,84	0,412		400	6000		
8	9	12	1,8	1,05		16,3	1	6,52	±0,058	0,614		360	3600	
9	10	14	2	1,15	18,8	1,1	7,63	0,934			325	2600		
10	11	15	2	,25	20,4	1,2	8,32	±0,07	1,179		300	2100		
12	13	18	2,5	1,35	23,4	1,3	10,45		1,570		280	1680		
15	16	24	3	1,55	29,4	1,5	12,61	±0,084	3,140	750				
19	20	31	3,5	1,80	37,6	1,75	15,92		5,780	350				
24	25	38	4	2,05	44,6	2	21,88	8,200	250					
30	32	42	4,5	2,55	52,6	2,5	25,80	13,800	100					

Atención: al hacer el pedido, hay que tener en cuenta nuestras normas de embalado.

Material : INOX A4 AISI 3161 (WN 1 4435) – Rkg mm TOS/115 (HRC)

Anillos elásticos en acero inoxidable

DIN 471 Tipo E

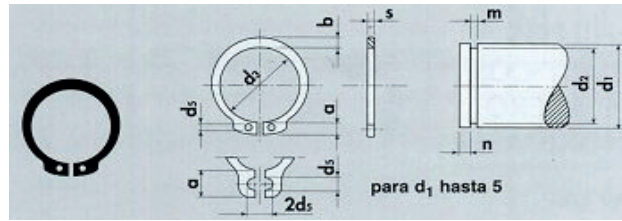

d ₁	Dimensión alojamiento			Dimensión anillo					Peso kg/1000			
	d ₂	m H13	n min	S	d ₃ max	a max	b ~	d ₅ min				
4	3,8	+0 -0,048	0,50	0,3	0,40	+0 -0,05	3,7	+0,04 -0,15	2,2	0,9	1	0,034
5	4,8		0,70	0,3	0,60		4,7		2,5	1,1	1	0,081
6	5,7		0,80	0,5	0,70		5,6	2,7	1,3	1,2	0,121	
7	6,7	+0 -0,06	0,90	0,5	0,8	+0,06 -0,18	6,5	+0,10 -0,36	3,1	1,4	1,2	0,189
8	7,6		0,90	0,6	0,8		7,4		3,2	1,5	1,2	0,220
9	8,6		1,10	0,6	1		8,4		3,3	1,7	1,2	0,368
10	9,6	+0 -0,11	1,10	0,6	1	+0,06	9,3	+0,10 -0,36	3,3	1,8	1,5	0,402
11	10,5		1,10	0,8	1		10,2		3,3	1,8	1,5	0,445
12	11,5		1,10	0,8	1		11		3,3	1,8	1,7	0,469
13	12,4		1,10	1,9	1		11,9		3,4	2,0	1,7	0,571
14	13,4		1,10	0,9	1		12,9		3,5	2,1	1,7	0,644
15	14,3		1,10	1,1	1		13,8		3,6	2,2	1,7	0,704
16	15,2		1,10	1,2	1		14,7		3,7	2,2	1,7	0,771
17	16,2		1,10	1,2	1		15,7		3,8	2,3	1,7	0,881
18	17,0		1,30	1,5	1,2		16,5		3,9	2,4	2	1,154
19	18,0		1,30	1,5	1,2		17,5		3,9	2,5	2	1,230
20	19,0	+0 -0,13	1,30	1,5	1,2	+0,06	18,5	+0,21 -0,42	4,0	2,6	2	1,321
21	20,0		1,30	1,5	1,2		19,5		4,1	2,7	2	1,450
22	21,0		1,30	1,5	1,2		20,5		4,2	2,8	2	1,599
23	22,0	+0 -0,21	1,30	1,7	1,2	+0,06	21,5	+0,21 -0,42	4,3	2,9	2	1,724
24	22,9		1,30	1,7	1,2		22,2		4,4	3,0	2	1,776
25	23,9		1,30	1,7	1,2		23,2		4,4	3,0	2	1,907
26	24,9		1,30	1,7	1,2		24,2		4,5	3,1	2	1,980
27	25,6		1,30	1,7	1,2		24,9		4,6	3,1	2	2,149
28	26,6		1,60	2,1	1,5		25,9		4,7	3,2	2	2,781
29	27,6		1,60	2,1	1,5		26,9		4,8	3,4	2	3,027
30	28,6		1,60	2,1	1,5		27,9		5,0	3,5	2	3,335
31	29,3	+0 -0,25	1,60	2,6	1,5	+0,06	28,6	-0,25 -0,5	5,0	3,5	2,5	3,228
32	30,3		1,60	2,6	1,5		29,6		5,2	3,6	2,5	3,430
33	31,3		1,60	2,6	1,5		30,5		5,2	3,7	2,5	3,917
34	32,3		1,60	2,6	1,5		31,5		5,4	3,8	2,5	4,086
35	33,0		1,60	3	1,5		32,2		5,6	3,9	2,5	4,329
36	34,0		1,85	3	1,75		33,2		5,6	4,0	2,5	4,860
37	35,0		1,85	3	1,75		34,2		5,7	4,1	2,5	5,300
38	36,0		1,85	3	1,75		35,2		5,8	4,2	2,5	6,360
39	37,0		1,85	3,8	1,75		36		5,9	4,3	2,5	5,650
40	37,5		1,85	3,8	1,75		36,5		6,0	4,4	2,5	5,420

Material: INOX AISI 420 MoV (para d1 hasta 27) WN 1.4116

Anillos elásticos en acero inoxidable

DIN 471 Tipo E

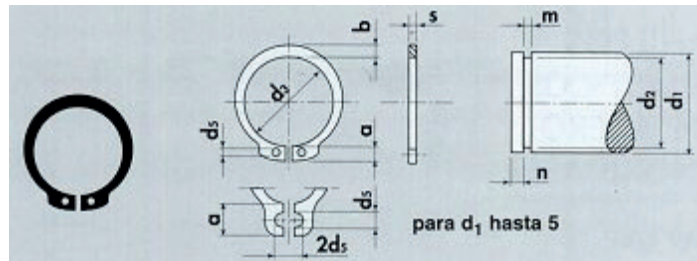

d ₁	Dimensión alojamiento			Dimensión anillo				Peso kg/1000				
	d ₂	m H13	n min	S	d ₃ max	a max	b ~		d ₅ min			
41	38,5	+0 -0,25	1,85	3,8	1,75	+0 -0,06	37,5	+0,39 -0,9	6,2	4,5	2,5	6,550
42	39,5		1,85	3,8	1,75		38,5		6,5	4,5	2,5	6,620
44	41,5		1,85	3,8	1,75		40,5		6,6	4,6	2,5	6,820
45	42,5		1,85	3,8	1,75		41,5		6,7	4,7	2,5	7,100
46	43,5		1,85	3,8	1,75		42,5		6,7	4,8	2,5	7,290
47	44,5		1,85	3,8	1,75		43,5		6,8	4,9	2,5	7,690
48	45,5		1,85	3,8	1,75		44,5		6,9	5,0	2,5	7,960
50	47,0		2,15	4,5	2		45,8		6,9	5,1	2,5	9,750
52	49,0	2,15	4,5	2	47,8	7,0	5,2	2,5	10,100			
54	51,0	+0 -0,30	2,15	4,5	2	+0 -0,07	19,8	+0,46 -1,1	7,1	5,3	2,5	10,700
55	52,0		2,15	4,5	2		50,8		7,2	5,4	2,5	10,900
56	53,0		2,15	4,5	2		51,8		7,3	5,5	2,5	11,280
57	54,0		2,15	4,5	2		52,8		7,3	5,5	2,5	11,800
58	55,0		2,15	4,5	2		53,8		7,3	5,6	2,5	12,090
60	57,0		2,15	4,5	2		55,8		7,4	5,8	2,5	12,570
62	59,0		2,15	4,5	2		57,8		7,5	6,0	2,5	14,030
63	60,0		2,15	4,5	2		58,8		7,6	6,2	2,5	14,850
65	62,0		2,65	4,5	2,5		60,8		7,8	6,3	3	19,310
67	64,0		2,65	4,5	2,5		62,5		7,9	6,4	3	20,900
68	65,0		2,65	4,5	2,5		63,5		8,0	6,5	3	21,010
70	67,0		2,65	4,5	2,5		65,5		8,1	6,6	3	21,730
72	69,0		2,65	4,5	2,5		67,5		8,2	6,8	3	23,490
75	72,0		2,65	4,5	2,5		70,5		8,4	7,0	3	24,770
77	74,0		2,65	4,5	2,5		72,5		8,5	7,2	3	25,800
78	75,0		2,65	4,5	2,5		73,5		8,6	7,3	3	26,900
80	76,5	2,65	5,3	2,5	74,5	8,6	7,4	3	27,120			
82	78,5	2,65	5,3	2,5	76,5	8,7	7,6	3	27,430			
85	81,5	+0 -0,35	3,15	5,3	3	+0 -0,08	79,5	+0,54 -1,3	8,7	7,8	3	37,300
87	83,5		3,15	5,3	3		81,5		8,8	7,9	3,5	39,000
88	84,5		3,15	5,3	3		82,5		8,8	8,0	3,5	39,600
90	86,5		3,15	5,3	3		84,5		8,8	8,2	3,5	39,890
92	88,5		3,15	5,3	3		86,5		9,0	8,4	3,5	43,800
95	91,5		3,15	5,3	3		89,5		9,4	8,6	3,5	45,000
97	93,5		3,15	5,3	3		91,5		9,4	8,8	3,5	52,310
98	94,5		3,15	5,3	3		82,5		9,5	9,0	3,5	48,950
100	96,5		3,15	5,3	3		94,5		9,6	9,0	3,5	479,720

Material: INOX AISI 420 MoV (para d1 hasta 27) WN 1.4116

Anillos elásticos en acero inoxidable

DIN 472 Tipo I

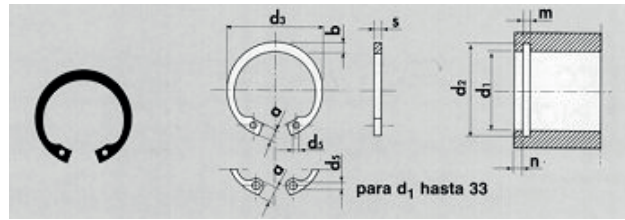

d ₁	Dimensión alojamiento				Dimensión anillo				Peso kg/1000		
	d ₂		m H13	n min	S	d ₃	a max	b ~		d ₅ min	
8	8,4	+0,09	0,90	0,6	0,8	+0	8,7	2,4	1,1	1	0,116
9	9,4	-0	0,90	0,6	0,8	-0,05	9,8	2,5	1,3	1	0,146
10	10,4	+0,11 -0	1,10	0,6	1	+0,36 -0,10	10,8	3,2	1,5	1,2	0,261
11	11,4		1,10	0,6	1		11,8	3,3	1,7	1,2	0,289
12	12,5		1,10	0,8	1		13	3,4	1,8	1,5	0,309
13	13,6		1,10	0,9	1		14,1	3,6	1,9	1,5	0,353
14	14,6		1,10	0,9	1		15,1	3,7	2,0	1,7	0,421
15	15,7		1,10	1,1	1		16,2	3,7	2,0	1,7	0,481
16	16,8		1,10	1,2	1		17,3	3,8	2,1	1,7	0,510
17	17,8		1,10	1,2	1		18,3	3,9	2,2	1,7	0,568
18	19,0	+0,13 -0	1,10	1,5	1	19,5	4,1	2,2	2	0,648	
19	20,0		1,10	1,5	1	20,5	4,1	2,3	2	0,682	
20	21,0		1,10	1,5	1	21,5	4,2	2,4	2	0,743	
21	22,0		1,10	1,5	1	22,5	4,2	2,5	2	0,803	
22	23,0	+0,21 -0	1,10	1,5	1	23,5	4,2	2,5	2	0,875	
23	24,1		1,30	1,8	1,2	24,6	4,2	2,6	2	1,140	
24	25,2		1,30	1,8	1,2	25,9	4,4	2,7	2	1,270	
25	26,2		1,30	1,8	1,2	26,9	4,5	2,8	2	1,320	
26	27,2		1,30	1,8	1,2	27,9	4,7	2,9	2	1,440	
27	28,4		1,30	2,1	1,2	29,1	4,7	2,9	2	1,530	
28	29,4		1,30	2,1	1,2	30,1	4,8	3,0	2	1,600	
29	30,4		1,30	2,1	1,2	31,1	4,8	3,0	2	1,700	
30	31,4	+0,25 -0	1,30	2,1	1,2	32,1	4,8	3,2	2	1,820	
31	32,7		1,30	2,6	1,2	33,4	5,2	3,2	2,5	1,973	
32	33,7		1,30	2,6	1,2	34,4	5,4	3,3	2,5	2,070	
33	34,7		1,30	2,6	1,2	35,5	5,4	3,3	2,5	2,240	
34	35,7		1,60	2,6	1,5	36,5	5,4	3,4	2,5	2,870	
35	37		1,60	3	1,5	37,8	5,4	3,5	2,5	2,970	
36	38		1,60	3	1,5	38,8	5,4	3,6	2,5	3,110	
37	39		1,60	3	1,5	39,8	5,5	3,7	2,5	3,250	
38	40	1,60	3	1,5	40,8	5,5	3,8	2,5	3,520		
39	41	1,60	3,5	1,5	42	5,6	3,9	2,5	3,810		
40	42,5	+0,09 -0,39	1,85	3,8	1,75	43,5	5,8	4,0	2,5	4,580	
41	43,5		1,85	3,8	1,75	44,5	5,9	4,1	2,5	5,080	
42	44,5		1,85	3,8	1,75	45,5	5,9	4,2	2,5	5,260	
43	45,5		1,85	3,8	1,75	46,5	5,9	4,2	2,5	5,480	
44	46,5		1,85	3,8	1,75	47,5	6,0	4,2	2,5	5,560	

Material: INOX AISI 420 MoV (para d1 hasta 27) WN 1.4116

Anillos elásticos en acero inoxidable

DIN 472 Tipo I

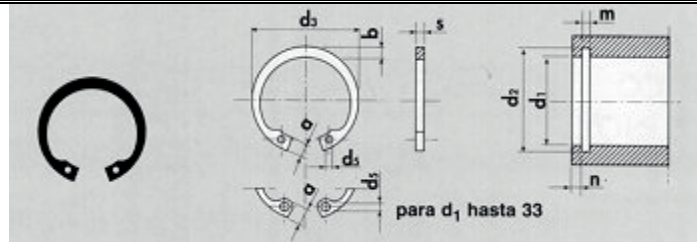

d ₁	Dimensión alojamiento			Dimensión anillo				Peso kg/1000				
	d ₂	m H13	n min	S	d ₃	a max	b ~		d ₅ min			
45	47,5	+0,25 -0	1,85	3,8	1,75	+0 -0,06	48,5	+0,09 -0,39	6,2	4,3	2,5	5,860
46	48,5		1,85	3,8	1,75		49,5	6,3	4,4	2,5	6,100	
47	49,5	+0,30 -0	1,85	3,8	1,75	+0 -0,07	50,5	+1,1 -0,46	6,4	4,4	2,5	6,740
48	50,5		1,85	3,8	1,75		51,5		6,4	4,5	2,5	6,530
49	51,5		1,85	3,8	1,75		52,5		6,5	4,5	2,5	7,050
50	53		2,15	4,5	2		54,2		6,5	4,6	2,5	8,370
51	54		2,15	4,5	2		55,2		6,5	4,7	2,5	8,600
52	55		2,15	4,5	2		56,2		6,7	4,7	2,5	8,340
53	56		2,15	4,5	2		57,2		6,7	4,9	2,5	9,380
54	57		2,15	4,5	2		58,2		6,7	5,0	2,5	9,420
55	58		2,15	4,5	2		59,2		6,8	5,0	2,5	9,560
56	59		2,15	4,5	2		60,2		6,8	5,1	2,5	10,000
57	60	+0,35 -0	2,15	4,5	2	+0 -0,08	61,2	+1,3 -0,54	6,8	5,1	2,5	10,170
58	61		2,15	4,5	2		62,2		6,9	5,2	2,5	10,680
60	63		2,15	4,5	2		64,2		7,3	5,4	2,5	10,820
62	65		2,15	4,5	2		66,2		7,3	5,5	2,5	11,190
63	66		2,15	4,5	2		67,2		7,3	5,6	2,5	11,690
65	68		2,65	4,5	2,5		69,2		7,6	5,8	3	16,100
67	70		2,65	4,5	2,5		71,5		7,7	6,0	3	17,340
68	71		2,65	4,5	2,5		72,5		7,8	6,1	3	17,920
70	73		2,65	4,5	2,5		74,5		7,8	6,2	3	18,640
72	75		2,65	4,5	2,5		76,5		7,8	6,4	3	19,000
75	78	2,65	4,5	2,5	79,5	7,8	6,	3	21,150			
77	80	+0,35 -0	2,65	4,5	2,5	+0 -0,08	81,5	+1,3 -0,54	7,9	6,7	3	22,750
78	81		2,65	4,5	2,5		82,5		8,5	6,8	3	23,040
80	83,5		2,65	5,3	2,5		85,5		8,5	7,0	3	24,310
82	85,5		2,65	5,3	2,5		87,5		8,5	7,0	3	24,900
85	88,5		3,15	5,3	3		90,5		8,6	7,2	3,5	31,900
87	90,5		3,15	5,3	3		92,5		8,6	7,3	3,5	34,000
88	91,5		3,15	5,3	3		93,5		8,6	7,4	3,5	35,120
90	93,5		3,15	5,3	3		95,5		8,6	7,6	3,5	35,420
92	95,5		3,15	5,3	3		97,5		8,7	7,8	3,5	38,170
95	98,5		3,15	5,3	3		100,5		8,8	8,1	3,5	40,450
97	100,5	3,15	5,3	3	102,5	8,8	8,2	3,5	40,320			
98	101,5	3,15	5,3	3	103,5	9,0	8,3	3,5	40,800			
100	103,5	3,15	5,3	3	105,5	9,2	8,4	3,5	43,150			

Material: INOX AISI 420 MoV (para d1 hasta 27) WN 1.4116

Chavetas

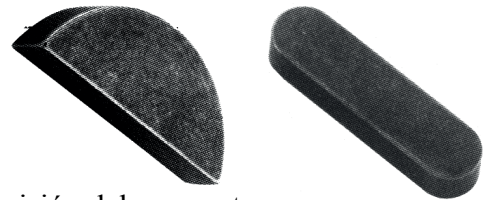

La lengüeta o chaveta normalmente es usada para la transmisión del momento torsor del eje al cubo.

Chaveta según la normativa UNI 6604-69 – din 6885

Forma A: los extremos con forma redondeada, con radio par hacia mitad de la base.

Forma B: los extremos rectos.

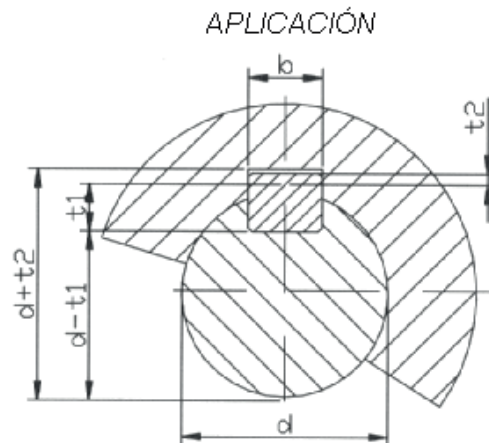
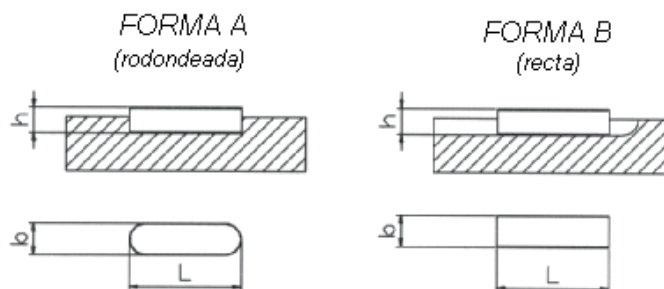

Material:

- Acero C45 con $R 59 \text{ daN/mm}^2$
- Acero inox AISI 316 con $R 59 \text{ daN/mm}^2$

La relación entre diámetro de eje y la sección de la chaveta se indica en la tabla de dimensiones de la pagina siguiente, si se refiere a las de uso normal.

El empleo de chavetas de sección más pequeña es posible si su resistencia es suficiente al esfuerzo que debe transmitir. El empleo de chavetas de sección más grande es desaconsejado.

En el caso de exigencia particular las formas A y B pueden ser combinadas, es decir un extremo redondeado y otro recto. En tal caso el símbolo de la forma es C.

En las tablas de a continuación también encontramos chavetas con secciones o largo especiales no unificados, el material y la tolerancia son las mismas que aquellas unificadas según la norma UNI 6604-69 – DIN 6885.

Tabla de tolerancia de chavetas y chaveteros de alojamiento (mm)

Campo de aplicación		Chaveta			Chavetero											
		Sección		Largo							Profundidad					
		Diámetro eje d	Dimen normal b x h	Toleran sobre		Dim. nom. b	Tolerancia sobre b						Eje		Cubo	
				b^{h9}	h*		Por eje			Por cubo			t1		t2	
					H9	N9	P9	D10	Js9	P9	Nom	Tol.	Nom	Tol.		
De Hasta	6 8	2x2	0	0	2							1,2		1		
Más de hasta	8 10	3x3	-0,025	-0,025	3	+0,025 0	-0,004 0	-0,006 -0,031	+0,060 +0,020	±0,012	-0,006 -0,031	1,8		1,4		
Más de Hasta	10 12	4x4			4							2,5	+0,1 0	1,8	+0,1 0	
Más de Hasta	12 17	5x5	0	0	5	+0,030 0	0 -0,030	-0,012 -0,042	+0,078 +0,030	±0,015	-0,012 -0,042	3		2,3		
Más de Hasta	17 22	6x6			6							3,5		3,5		
Más de Hasta	22 30	8x7	0		8							5		3,3		
Más de Hasta	30 38	10x8	-0,036		10	+0,036 0	0 -0,036	-0,015 -0,051	+0,098 +0,040	±0,018	-0,015 -0,051	5		3,3		
Más de Hasta	38 44	12x8		0	12							5		3,3		
Más de Hasta	44 50	14x9		-0,090	14							5,5		3,8		
Más de Hasta	50 58	16x10	0		16	+0,043 0	0 -0,043	-0,018 -0,061	+0,120 +0,050	±0,021	-0,018 -0,061	6		4,3		
Más de Hasta	58 60	18x11			18							7		4,4		
Más de Hasta	65 75	20x12			20							7,5	+0,2 0	4,9	+0,2 0	
Más de Hasta	75 85	22x14	0	0	22							9		5,4		
Más de Hasta	85 95	25x14	-0,052	-0,110	25	+0,052 0	0 -0,052	-0,022 -0,074	+0,149 +0,065	±0,026	-0,022 -0,074	9		5,4		
Más de Hasta	95 110	28x16			28							10		6,4		
Más de Hasta	110 130	32x18			32							11				
Más de Hasta	130 150	36x20			36							12		8,4		
Más de Hasta	150 170	40x22	0		40	+0,062 0	0 -0,062	-0,026 -0,088	+0,180 +0,080	±0,031	-0,026 -0,088	13		9,4		
Más de Hasta	170 200	45x25			45							15		10,4		
Más de Hasta	200 230	50x28			50							17		11,4		
Más de Hasta	230 260	56x32			56							20		12,4		
Más de Hasta	260 290	63x32			63							20	+0,3 0	12,4	+0,3 0	
Más de Hasta	290 330	70x36	0	-0,074	70	+0,074 0	0 -0,074	-0,032 -0,106	+0,220 +0,100	±0,037	-0,032 -0,106	22		14,4		
Más de Hasta	330 380	80x40			80							25		15,4		
Más de Hasta	380 440	90x45			90	+0,087 0						28		17,4		
Más de hasta	440 500	100x50	0	-0,087	100		0 -0,087	-0,037 -0,124	+0,260 +0,120	±0,043	-0,037 -0,124	31		19,5		

* La tolerancia es **h9** para la sección cuadrada y **h11** para la rectangular.

Tabla de tolerancia de longitudes L (mm)

Longitud		Tolerancia chaveta		Tolerancia chavetero	
Hasta	28	0	-0,20	+0,20	0
Más Hasta	28 80	0	-0,30	+0,30	0
Más de	80	0	-0,50	+0,50	0

Chavetas de disco según normativa DIN 6888 - ISO 3912

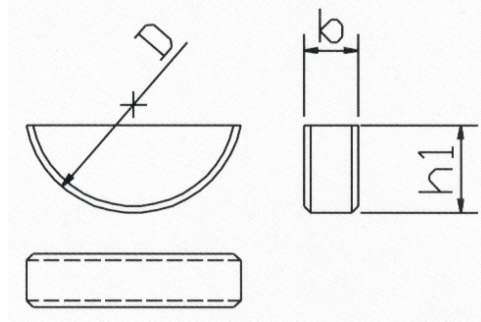

Material:

- Acero C45 con R59 daN/mm²

La relación entre diámetro de eje y la sección de la chaveta se indica en la tabla de más de abajo, en lo referente a la de empleo normal.

El empleo de chavetas de sección más pequeña es posible si su resistencia es suficiente el esfuerzo a transmitir. El empleo de chavetas de sección más grande es desaconsejable.

Tabla de tolerancia de chavetas de disco (mm)

Diámetro del eje d				Chaveta estandar bxh 1x D o forma equival.	CHAVETA							
Par a transmitir		Para posicionamiento			Base b		Altura h1		diámetro d		Angulo/radio	
>	<	>	<		Nom	Tol..h9	Nom	Tol.h11	Nom	Tol.h12	Min.	Max.
3	4	3	4	1x1,4x4	1	0 -0,025	1,4	0 -0,060	4	0 -0,120	0,16	0,25
4	5	4	6	1,5x2,6x7	1,5		2,6		7			
5	6	6	8	2x2,6x7	2		2,6		7			
6	7	8	10	2x3,7x10	2		3,7	0 -0,075	10	-0,150		
7	8	10	12	2,5x3,7x10	2,5		3,7		10			
8	10	12	15	3x5x13	3		5	0 -0,180	13	0 -0,210		
10	12	15	18	3x6,5x16	3		6,5		16			
12	14	18	20	4x6,5x16	4	6,5	16					
14	16	20	22	4x7,5x19	4	0 -0,030	7,5	0 -0,090	19	0 -0,210	0,25	0,40
16	18	22	25	5x6,5x16	5		6,5		16			
18	20	25	28	5x7,5x19	5		7,5		19			
20	22	28	32	5x9x22	5		9		22			
22	25	32	36	6x9x22	6		9		22			
25	28	36	40	6x10x25	6		10		25			
28	32	40	-	8x11x28	8	0 -0,110	11	28	0,40	0,60		
32	38	-	-	10x13x32	10		13	32				

Para la chaveta de dimensiones no normalizadas la tolerancia de referencia es la misma.



Tabla tolerancia de chaveteros para chavetas de disco (mm)

Diametro del eje d				Chaveta estandar bxh 1x D o forma equival.	CHAVETA									
Par a transmitir		Para posicion			Base b			profundidad				Radio R		
>	<	>	<		nom	Tipo de acoplamiento			eje		cubo		max	min
						eje	cubo	eje/cubo	t1		t2			
					Tol.N9	Tol.Js9	Tol.P9	nom	tol	nom	tol			
3	4	3	4	1x1,4x4	1,0	-0,004 -0,029	+0,012 -0,012	-0,006 -0,031	1,0	+0,1 0	0,6	0,16	0,08	
4	5	4	6	1,5x2,6x7	1,5				2,0		0,8			
5	6	6	8	2x2,6x7	2,0				1,8		1,0			
6	7	8	10	2x3,7x10	2,0				2,9		1,0			
7	8	10	12	2,5x3,7x10	2,5				2,7		1,2			
8	10	12	15	3x5x13	3,0				3,8		1,4			
10	12	15	18	3x6,5x16	3,0	5,3	1,4	+0,1 0	0,25	0,16				
12	14	18	20	4x6,5x16	4,0	5,0	1,8							
14	16	20	22	4x7,5x19	4,0	6,0	1,8							
16	18	22	25	5x6,5x16	5,0	4,5	2,3							
18	20	25	28	5x7,5x19	5,0	5,5	2,3							
20	22	28	32	5x9x22	5,0	7,0	2,3							
22	25	32	36	6x9x22	6,0	6,5	2,8	+0,3 0	0,40	0,25				
25	28	36	40	6x10x25	6,0	7,5	2,8							
28	32	40	-	8x11x28	8,0	8,0	3,3							
32	38	-	-	10x13x22	10,0	-0,036	+0,018 -0,018	-0,015 -0,051	10,0	3,3	3,3			

Para la chaveta de dimensiones no normalizadas la tolerancia de referencia es la misma.

UNI 6604 – DIN 6885

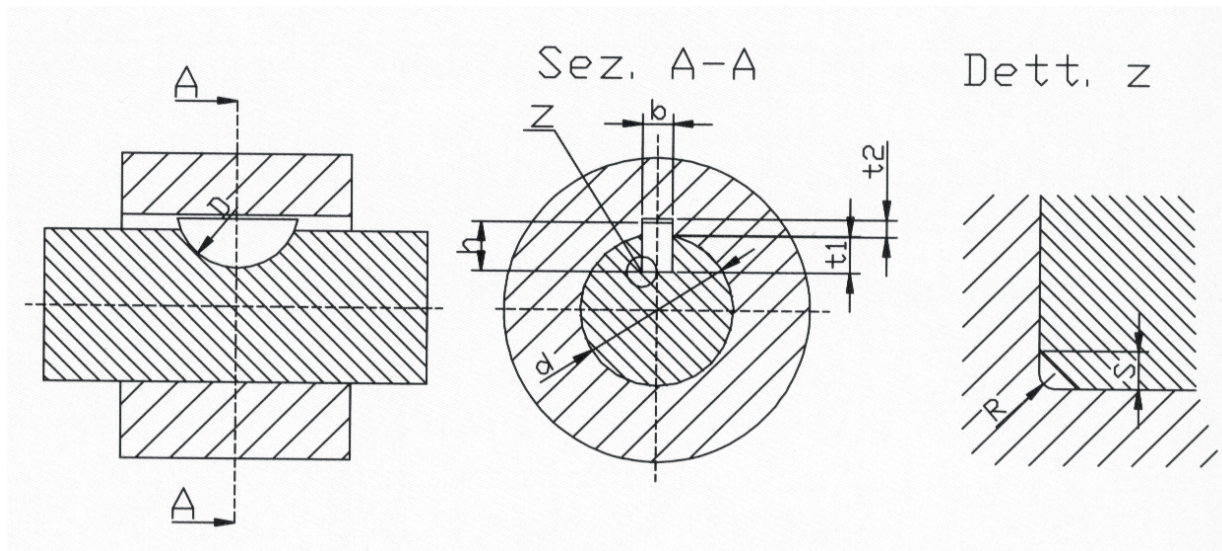
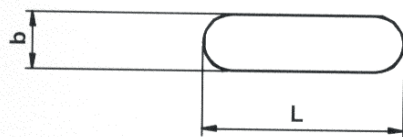

forma A

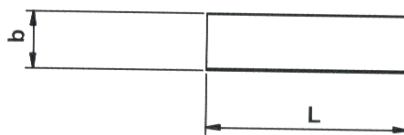

forma B

b ^{h9} x h ^{h11}	L mm																			Chavetero			
	8	10	12	14	15	16	18	20	22	25	28	30	32	35	36	40	45	50			t ₁	d+t ₂	
3 x 3	8	10	12	14	15	16	18	20	22	25	28	30	32	35	36	40	45	50			1,8	d+1,4	
4 x 4	8	10	12	14	15	16	18	20	22	25	28	30	32	35	36	40	45	50			2,5	d+1,8	
5 x 5	10	12	14	15	16	18	20	22	25	28	30	32	35	36	40	45	50	55	56	60	70	3	d+2,3
6 x 6	12	14	15	16	18	20	22	25	28	30	32	35	36	40	45	50	55	56	60	70	80	3,5	d+2,8
8 x 7	18	20	22	25	28	30	32	35	36	40	45	50	55	56	60	63	70	80	90	100	110	4	d+3,3
10 x 8	20	22	25	28	30	32	35	36	40	45	50	55	56	60	63	70	80	90	100	110	120	5	d+3,3
12 x 8	25	28	30	32	35	36	40	45	50	55	56	60	63	70	80	90	100	110	120	130	140	5	d+3,3
14 x 9	35	36	40	45	50	55	56	60	63	70	80	90	100	110	120	125	130	140	150			5,5	d+3,8
16 x 10	40	45	50	55	56	60	63	70	80	90	100	110	120	125	130	140	150					6	d+4,3
18 x 11	50	55	56	60	63	70	80	90	100	110	120	125	130	140	150	160						7	d+4,4
20 x 12	50	56	60	63	70	80	90	100	110	120	125	130	140	150	160	180	200					7,5	d+4,9
22 x 14	60	63	70	80	90	100	110	120	125	130	140	150	160	180	200	220	250					9	d+5,4
24 x 14	60	63	70	80	90	100	110	120	125	130	140	150	160	180	200	220	250					9	d+5,4
25 x 14	60	63	70	80	90	100	110	120	125	130	140	150	160	180	200	220	250					9	d+5,4
28 x 16	70	80	90	100	110	120	125	130	140	150	160	180	200	220	250	280	300					10	d+6,4
32 x 18	90	100	110	120	125	130	140	150	160	180	200	220	250	280	300	360						11	d+7,4
36 x 20	90	100	110	120	125	130	140	150	160	180	200	220	250	280	300							12	d+8,4
40 x 22	90	100	110	120	125	130	140	150	160	180	200	220	250	280	300							13	d+9,4
45 x 25	100	110	120	125	130	140	150	160	180	200	220	250	280	300								15	d+10,4

UNI 6604 – DIN 6885 INOX

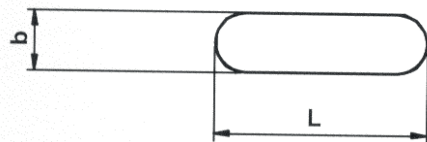

forma A

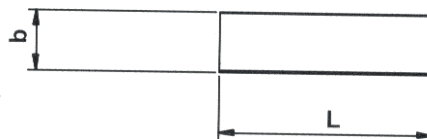

forma B

b ^{h9} x h ^{h11}	L mm																		Chavetero				
	10	12	14	15	16	18	20	22	25	28	30	32	35	36	40	45	50					t ₁	d+t ₂
3 x 3	10	12	14	15	16	18	20	22	25	28	30	32	35	36	40	45	50					1,8	d+1,4
4 x 4	10	12	14	15	16	18	20	22	25	28	30	32	35	36	40	45	50					2,5	d+1,8
5 x 5	10	12	14	15	16	18	20	22	25	28	30	32	35	36	40	45	50	55	60			3	d+2,3
6 x 6	12	14	15	16	18	20	22	25	28	30	32	35	36	40	45	50	55	60	70	80		3,5	d+2,8
8 x 7	15	20	22	25	28	30	32	35	36	40	45	50	55	60	70	80	90	100	110			4	d+3,3
10 x 8	20	22	25	28	30	32	35	36	40	45	50	55	60	70	80	90	100	110	120			5	d+3,3
12 x 8	25	28	30	32	35	36	40	45	50	55	60	70	80	90	100	110	120	130	140			5	d+3,3
14 x 9	35	36	40	45	50	55	60	70	80	90	100	110	120	130	140	150						5,5	d+3,8
16 x 10	40	45	50	55	60	70	80	90	100	110	120	130	140	150								6	d+4,3
18 x 11	50	55	60	70	80	90	100	110	120	130	140	150										7	d+4,4
20 x 12	50	60	70	80	90	100	110	120	130	140	150											7,5	d+4,9

NO NORMALIZADA – FORMA A

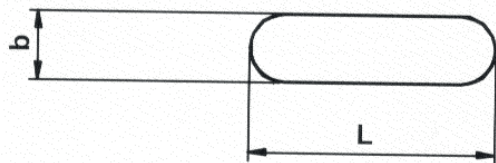

forma A



b ^{h9} x h ^{h11}	L mm																Chavetero	
																	t ₁	d+t ₂
5 x 4	10	15	18	20	25	30	35	40	45	50	55	60	65	70			2,5	d+1,8
6 x 4	12	15	18	20	25	30	35	40	45	50	55	60	65	70	80		2,5	d+1,8
6 x 5	12	15	18	20	25	30	35	40	45	50	55	60	65	70	75		3	d+2,3
7* x 7*	20	25	30	35	40	45	50	55	60	65	70	75	80	85	90	100	4	d+3,3
8 x 5	20	25	30	35	40	45	50	55	60	65	70	75	80	85	90	100	3	d+2,3
8 x 6	20	25	30	35	40	45	50	55	60	65	70	75	80	85	90	100	3,5	d+2,8
8 x 8	20	25	30	35	40	45	50	55	60	65	70	75	80	85	90	100	5	d+3,3
10 x 10	20	25	30	35	40	45	50	55	60	65	70	75	80	85	90	100	6	d+4,3
12 x 12	30	35	40	45	50	55	60	65	70	75	80	85	90	100	110	120	7,5	d+4,9
14* x 14*	30	35	40	45	50	55	60	65	70	75	80	85	90	100	110	120	9	d+5,4

* Tolerancia + 0,05

UNI 6604/A – DIN 6885/A CON LARGO ESPECIAL

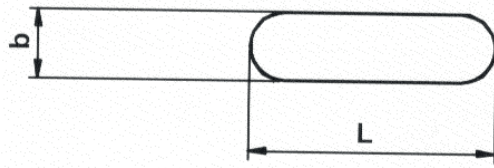

forma A



$b^{h9} \times h^{h11} \times L$ (mm)				
4 x 4 x 55	5 x 5 x 80	6 x 6 x 90	8 x 7 x 120	10 x 8 x 130
4 x 4 x 60	5 x 5 x 90	6 x 6 x 100	8 x 7 x 130	10 x 8 x 140
4 x 4 x 65	5 x 5 x 100	6 x 6 x 110	8 x 7 x 140	10 x 8 x 150
4 x 4 x 70	5 x 5 x 110	6 x 6 x 120	8 x 7 x 150	10 x 8 x 160
4 x 4 x 75	5 x 5 x 120	6 x 6 x 130	8 x 7 x 160	10 x 8 x 170
4 x 4 x 80	5 x 5 x 130	6 x 6 x 140	8 x 7 x 170	10 x 8 x 180
4 x 4 x 85	5 x 5 x 140	6 x 6 x 150	8 x 7 x 180	10 x 8 x 190
4 x 4 x 90	5 x 5 x 150	6 x 6 x 160	8 x 7 x 190	10 x 8 x 200
4 x 4 x 95		6 x 6 x 170	8 x 7 x 200	10 x 8 x 210
4 x 4 x 100		6 x 6 x 180	8 x 7 x 250	10 x 8 x 220
4 x 4 x 125		6 x 6 x 190		10 x 8 x 230
4 x 4 x 150		6 x 6 x 200		10 x 8 x 240
				10 x 8 x 280
				10 x 8 x 300
12 x 8 x 150	14 x 9 x 160	16 x 10 x 160	18 x 11 x 180	20 x 12 x 220
12 x 8 x 160	14 x 9 x 170	16 x 10 x 180	18 x 11 x 200	20 x 12 x 250
12 x 8 x 170	14 x 9 x 180	16 x 10 x 200	18 x 11 x 230	20 x 12 x 260
12 x 8 x 180	14 x 9 x 190	16 x 10 x 210	18 x 11 x 240	20 x 12 x 270
12 x 8 x 190	14 x 9 x 200	16 x 10 x 220	18 x 11 x 250	20 x 12 x 280
12 x 8 x 200	14 x 9 x 210	16 x 10 x 230	18 x 11 x 260	20 x 12 x 290
12 x 8 x 210	14 x 9 x 220	16 x 10 x 240	18 x 11 x 270	20 x 12 x 300
12 x 8 x 220	14 x 9 x 230	16 x 10 x 250	18 x 11 x 280	
12 x 8 x 250	14 x 9 x 240		18 x 11 x 290	
12 x 8 x 290	14 x 9 x 250		18 x 11 x 300	

CHAVETA DE DISCO UNI 6606 – DIN 6888

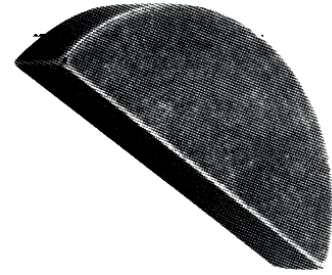
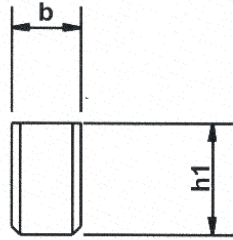
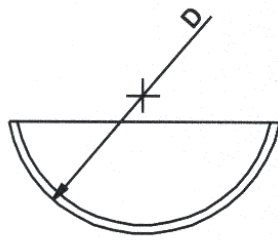

$b^{h9} \times h^{h11}$	L mm	d mm	Peso ≈ (kg)		$b^{h9} \times h^{h11}$	L mm	d mm	Peso ≈ (kg)
2 x 3,7	9,66	10	0,034		4 x 9	21,63	22	0,442
2,5 x 3,7			0,047		5 x 9			0,556
3 x 3,7			0,06		6 x 9			0,667
2 x 5	12,65	13	0,07		5 x 10	24,49	25	0,704
3 x 5			0,108		6 x 10			0,837
4 x 5			0,141		6 x 11	17,35	28	1,39
3 x 6,5	15,72	16	0,171		8 x 11			1,39
4 x 6,5			0,231		6 x 13	31,42	32	1,4
5 x 6,5			0,29		8 x 13			1,42
3 x 7,5	18,57	19	0,234		8 x 15	37,15	38	2,5
4 x 7,5			0,308		8 x 16	43,08	45	3,1
5 x 7,5			0,397		10 x 16			4,12

Juntas universales

Tipo Cruceta

Ø 42



Velocidad máxima 1000 tr/min
 Angulo máximo 34°
 Par de rotura ≥ 220 Nm
 Para angulos superiores a 34° consultar

En simple y en doble la junta universal a cruceta se pueden fabricar con los acoplamientos indicados en la tabla siguiente:

c: perfil acoplamiento	C1	Ø	ESTÁNDAR: ø15; ø17; ø20
	C2		ESTÁNDAR: ø19x14
	C3		ESTÁNDAR: 36 DIENTES 5/8" - 28 DIENTES / 40 DIVISIONES - 37 DIENTES ESPIRALES - 48 DIENTES DE 3/4" - 21 DIENTES ESPIRALES
	C4		ESTÁNDAR: 5 DIENTES / 27 DIVISIONES
	C5		CONSULTAR PARA ACOPLAMIENTOS DISTINTOS

Junta Simple Con Acoplamientos Abiertos

Junta Universal a Cruceta simple con acoplamientos abiertos para apriete con tornillo.

CÓDIGO	DIMENSIONES Y FORMAS	REFERENCIAS DE TIPOS (2)	b +/- 1
C1	Ø15	0734.**	39
C1	Ø15	2695.**	39
C1	Ø17	0311.**	39
C1	Ø17	2748.**	39
C1	Ø20	0839.**	39
C1	Ø20	2749.**	39
C2	Ø19x14	0309.**	39
C2	Ø19x14	0102.**	39
C3	36 DIENTES el 5/8"	0265.**	39
C4	5 DIVISIONES TEETH/27	0310.**	39
C4	5 DIVISIONES TEETH/27	0109.**	39

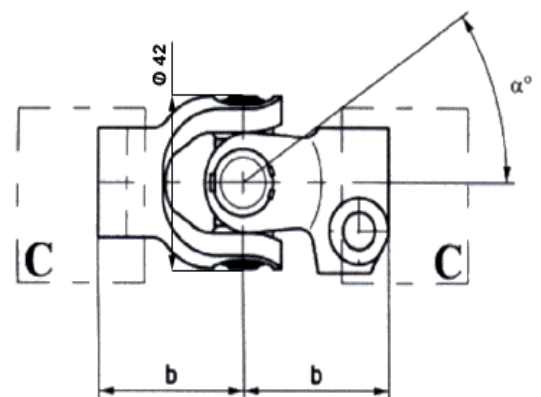

(2) Referencias de tipos

Sin pintar			
Sin tornillos	00	Con tornillos	90
Pintado			
Sin tornillos	01	Con tornillos	91

Juntas universales

Tipo Cruceta

Ø 42

Junta Doble Con Acoplamiento Abiertos

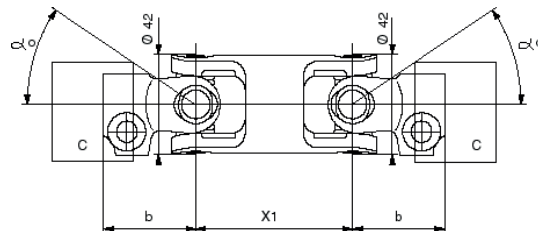
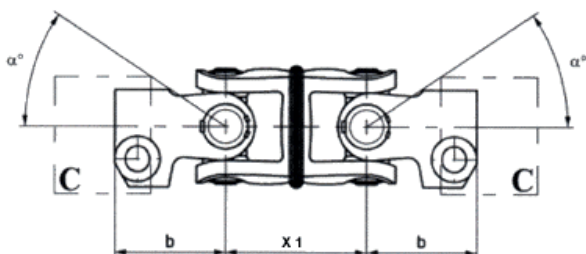

CODIGO	DIMENSIONES Y FORMAS	REFERENCIAS DE TIPOS (2)	b +/- 1	X1
C3	36 DENTS 5/8"	5087. **	39	50
C1	Ø15	5118. **	39	50
C1	Ø20	5119. **	39	50
C1	Ø17	5126. **	38,75	50
C1	Ø20	5152. **	38,75	66

Junta Simple Para Soldar

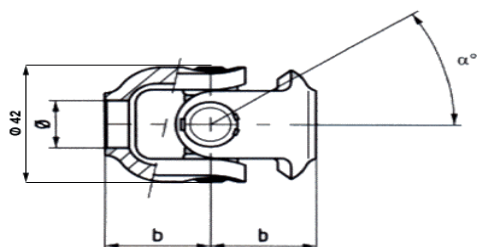

(2) Referencias de tipos			
Pintado	01	No pintado	00

CODE	DIMENSIONES Y FORMAS	REFERENCIAS DE TIPO (2)	b +/- 1
C1	Ø20	306.**	31
C1	Ø17	307.**	31
C1	Ø18	570.**	31

Bajo demanda es posible asociar dos diámetros distintos

Junta Simple a cruceta

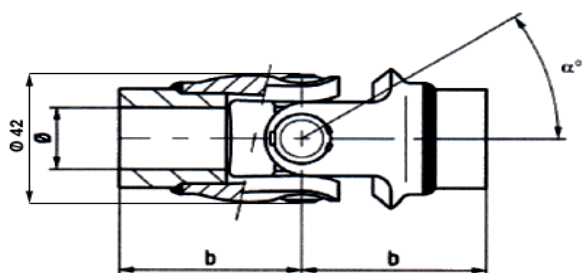

(2) Referencias de tipos			
Pintado	01	No pintado	00

CODE	DIMENSIONES Y FORMAS	REFERENCIAS DE TIPO (2)	b +/- 1
C1	Ø30	0886.**	31
C1	Ø25	5048.**	31
C1	Ø20	5107.**	31

Juntas universales



Tipo Cruceta

Ø 55



Velocidad máxima 1500 tr/min
 Angulo máximo 50°
 Par de rotura ≥ 400 Nm
 Para angulos superiores a 50° consultar

En simple y en doble la junta universal a cruceta se pueden fabricar con los acoplamientos indicados en la tabla siguiente:

c: perfil acoplamiento	C1	Ø	ESTÁNDAR: ø25
	C2		CONSULTAR
	C3		ESTÁNDAR: 54 DIENTES - 75 DIENTES - 79 DIENTES
	C4		CONSULTAR
	C5		CONSULTAR PARA ACOPLAMIENTOS DISTINTOS

Junta Simple Con Acoplamientos Abiertos

Junta Universal a Cruceta simple con acoplamientos abiertos para apriete con tornillo.

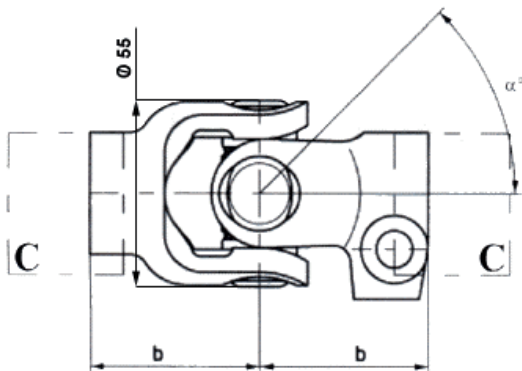

(2) Referencias de tipos			
Sin pintar			
Sin tornillos	00	Con tornillos	90
Pintado			
Sin tornillos	01	Con tornillos	91

CODE	DIMENSIONES Y FORMAS	REFERENCIAS DE TIPO (2)	b +/- 1
C1	Ø25	0947.**	60
C3	75 DIENTES	0638.**	60
C3	79 DIENTES	0639.**	60
C3	54 DIENTES	5104.**	60

Juntas universales

Tipo Cruceta

Ø 55

Junta Doble Con Acoplamiento Abiertos

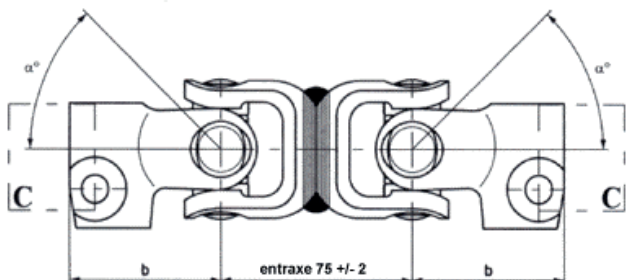

(2) Referencias de tipos			
Sin pintar			
Sin tornillos	00	Con tornillos	90
Pintado			
Sin tornillos	01	Con tornillos	91

CODE	DIMENSIONES Y FORMAS	REFERENCIAS DE TIPO (2)	b +/- 1
C1	Ø25	5022.**	60
C3	79 DIENTES	5125.**	60

Junta Simple Para Soldar

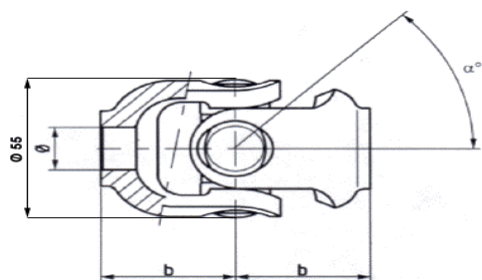

(2) Referencias de tipos			
Pintado	01	No pintado	00

CODE	DIMENSIONES Y FORMAS	REFERENCIAS DE TIPO (2)	b +/- 1
C1	Ø22	0244.**	44
C1	Ø27	5134.**	44

Bajo demanda es posible asociar dos diámetros distintos

Junta Simple a cruceta

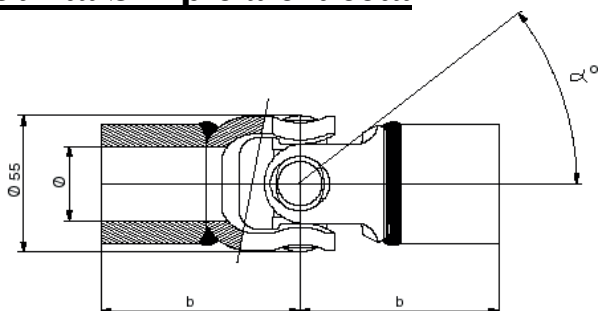

(2) Referencias de tipos			
Pintado	01	No pintado	00

CODE	DIMENSIONES Y FORMAS	REFERENCIAS DE TIPO (2)	b +/- 1
C1	Ø30	0291.**	80



Suministros Industriales del Tajo, S.A.

C/ Jarama 52, Polígono Industrial, 45007 Toledo (Spain)

Telf: (34) 925 23 22 00

Fax: (34) 925 23 21 47

sitasa@sitasa.com

www.sitasa.com

